

# ISIC

Solutions in Metal

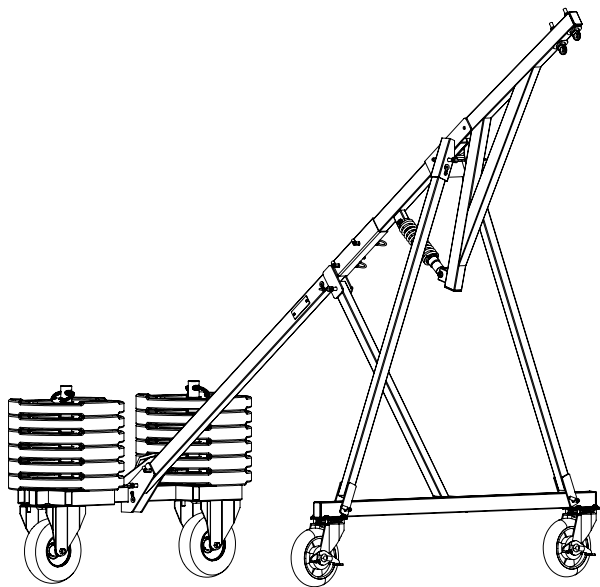

UK  
CA 0120

CE 0598



A Frame Anchor

**climb. work. rescue.**

## Deadweight Anchors

### DW200.3 A Frame

This DW200.3 A Frame is primarily designed and tested to be used as a portable anchor device for Rope Access (work positioning) systems/activities.

The DW200.3 A Frame has been tested in accordance with EN795: 2012 Type E by SATRA in the UK and CE marked accordingly.

The DW200.3 is also certified to UKCA Certification UK PPE Regulation 2016/425 (as retained in UK law and amended).

The unit has been further tested and found to meet the requirements of PD CEN/TS 16415: 2013 'anchor devices for two person rescue' and also the IRATA and SPRAT ICoP requirement that anchors for rope access must meet a 15kN static test.

For rope access standards requirements please refer to ISO 22846-1:2003, BS7985: 2002, BS EN12841: 2006, BS7883 or equivalent international standards and Codes of Practice.

#### Installation Considerations

- Roof surface is appropriate, i.e. Surface material, ballast, water, foreign matter, angle. All of these factors could affect the frictional resistance of the device and create a hazard

- All loose surface material should be removed before assembly and installation of the device

Users of this equipment shall be able to demonstrate either in-house expertise or hold suitable training certificates in Working at Height / industrial rope access

Rescue – The device has a Working Load Limit of 200kg (440lbs) and can be used for a 2 person load in a rescue situation in accordance with PD CEN/TS 16415: 2013

There must be sufficient free space beneath the user at the work area before each occasion of use, so that in the case of a dynamic event there will be no collision with the ground or other obstacles in the fall path.

### A General Limitations

1

$$X = \leq 5^\circ$$

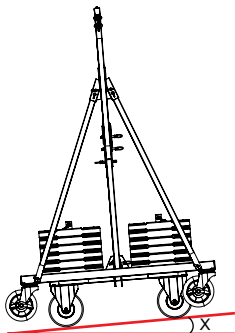
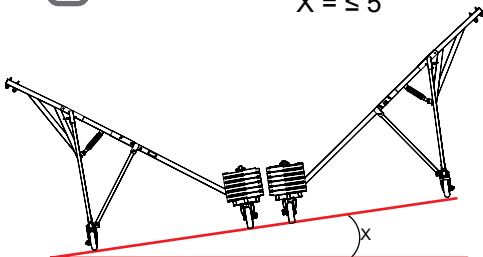

2

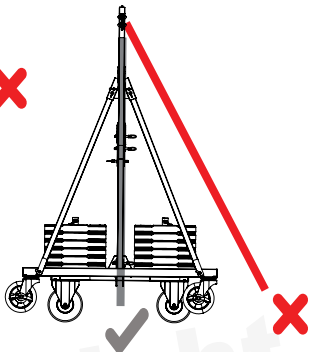
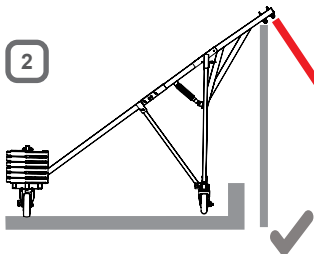

3

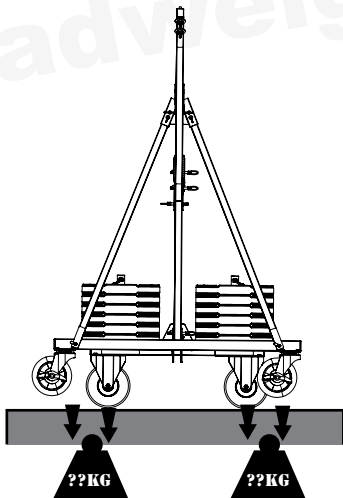

4

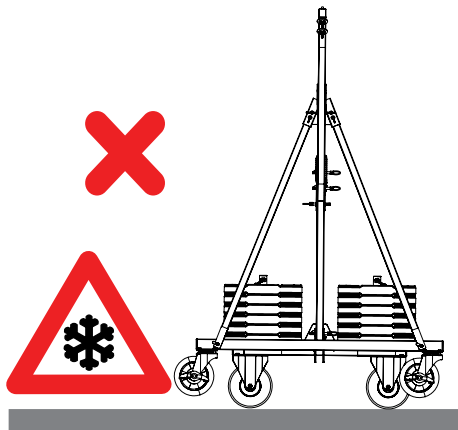

5

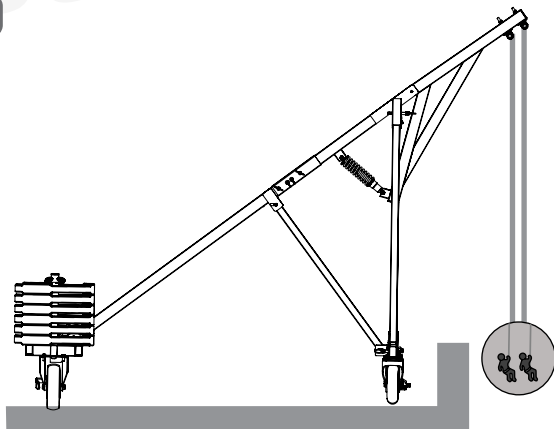

**[A] General Limitations**

1. The DW200.3 should not be used on a surface that slopes more than 5°.
2. The DW200.3 must be used so that the operator is in line with the equipment's direction to prevent the possibility of a pendulum occurring in the event of a fall
3. Ensure that the strength of the structure is adequate
4. The DW200.3 should not be used on frozen surfaces. The presence of ice may cause the unit to slip
5. The DW200.3 is for use by a single person. In the event of a rescue being required, the DW200.3 can be used with a 2-person load in accordance with PD CEN/TS 16415: 2013
6. Do not use DW200.3 anchor outside of its limitations, as outlined in this manual
7. The user shall be equipped with means of limiting the maximum dynamic forces exerted on the user during a dynamic event to less than 6kN
8. If the intention is to combine PFPE for Fall Arrest with the DW200.3, the user should seek guidance from the manufacturer as to its suitability. Always ensure that all components within a safety system are compatible and allow the system to function safely

**B Use**

1

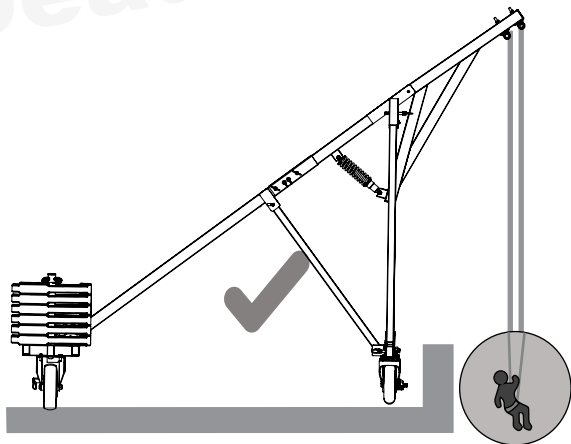

2

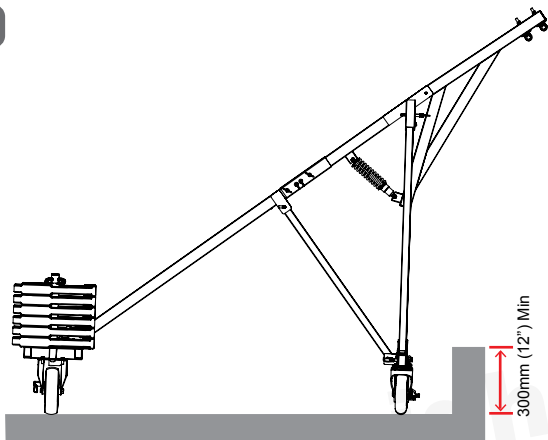

3

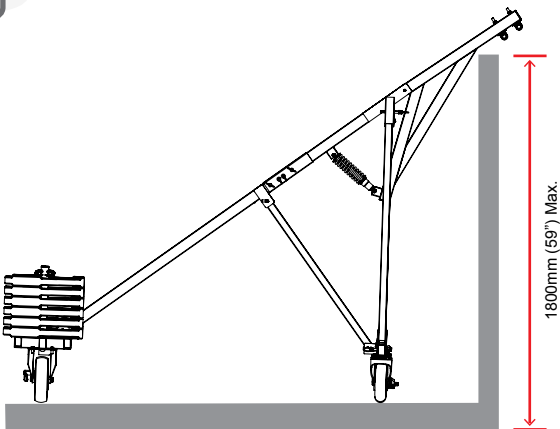

4

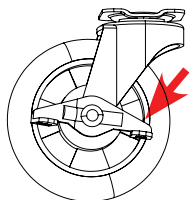

**Brake Off**

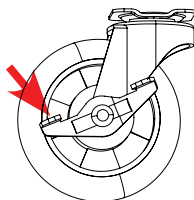

**Brake On**



5

Deadweight

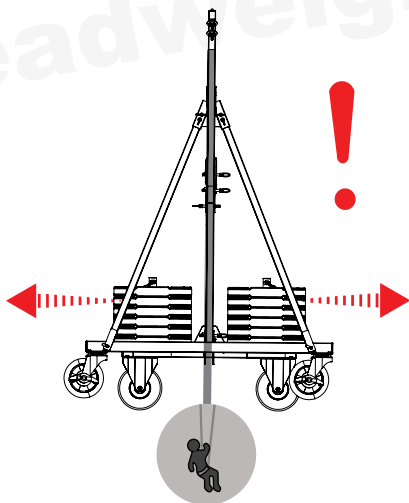

6

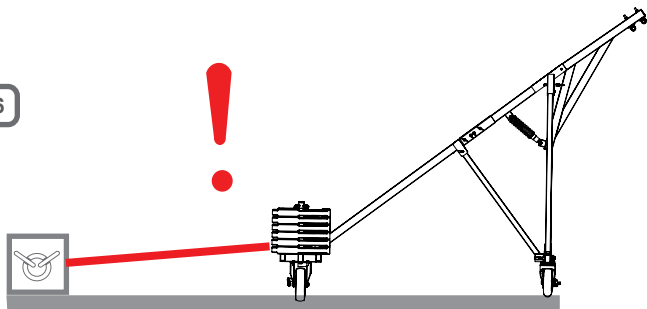

#### [B] Use

1. The DW200.3 is designed to be used as part of a roped access system with twin ropes, work positioning harness and associated equipment
2. The DW200.3 should be used with a parapet wall with a minimum height of 300mm (12")
3. The DW200.3 should be used with a parapet wall with a maximum height of 1800mm (59")
4. **Wheel brake operation:** To unlock the wheel, push down the braking lever on the side marked OFF. The wheel will now rotate. To lock the wheel, push DOWN the braking lever on the side marked ON.

**Fixed-wheel brake operation:** To unlock the wheel, pull the red locking bolt out and rotate 180° counter clockwise. The wheel will now rotate. To lock the wheel, reverse this process. The DW200.3 is available with a choice of Pneumatic or solid wheels. All 4 wheels used should be of the same type (solid OR Pneumatic).

5. If no parapet wall is available, then the DW200 may be tied back to a suitable anchor to prevent unintentional movement. Soft slings should be used around the rear wheel support assembly [11]

**This option should be thoroughly risk assessed by a competent person.**

6. All weights (12 x 25kg Olympic Plates) must be used at all times. Weights are secured by passing a karabiner through the 'weight locator pole' holes. If the Olympic weights are too deep for the built in mount pole, the mount pole may be extended by screwing in the extension pole (supplied separately). The weights can then be added and secured by clipping a karabiner through the holes at the top of the weight pole.



**C** General Misuse

1

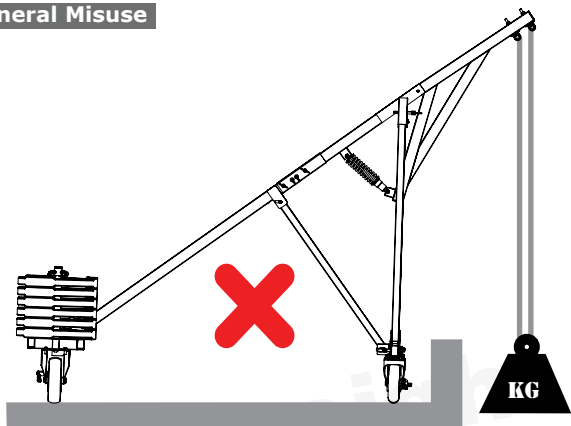

2

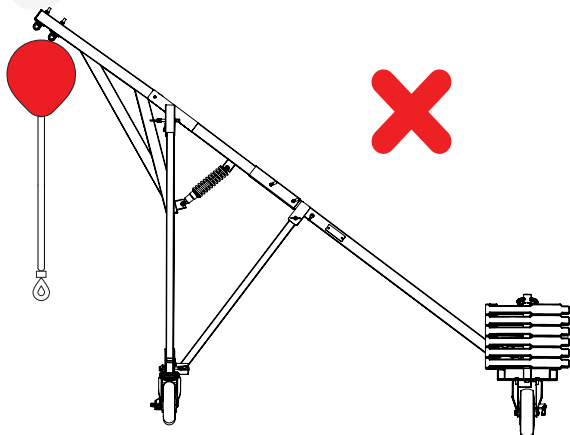

### [C] Misuse

1. The Deadweight should only be used for people. It should not be used for suspending loads
2. Do not use the Deadweight as an anchor for Self Retracting Lanyards

**IMPORTANT:** The DW200.3 A-Frame must always be used with a full set of 'Olympic' Weight plates (set = 12 x 25kg weights). Weights may be secured by clipping a karabiner through the hole at the top of the weight-locator. Alternately, a padlock can be used, in order prevent tampering of the device, during use.

### D Nomenclature

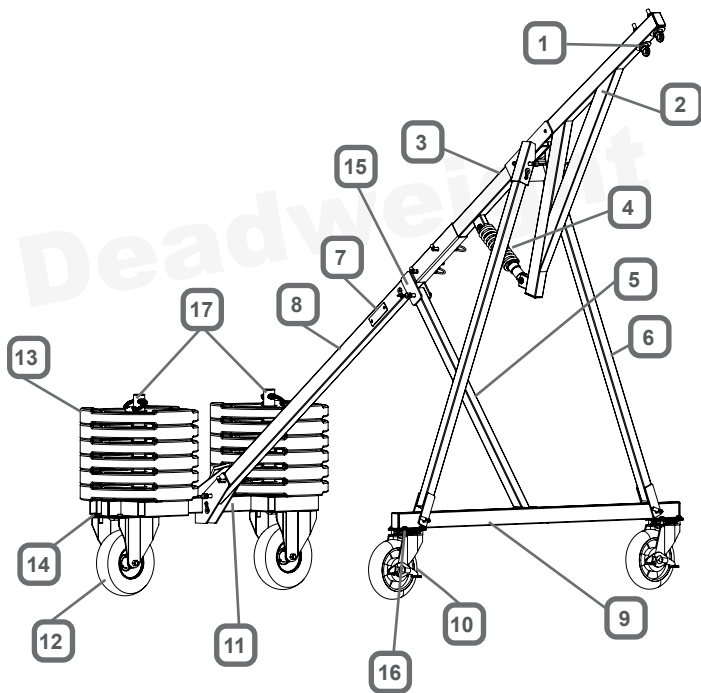

**[D] Nomenclature**

1. Anchor Points
2. Top Boom
3. Middle Boom
4. Shock Absorber
5. Centre Stay
6. A-Frame Leg
7. Manufacturers Plate
8. Lower Boom
9. Front Wheel Support Bar
10. Swivel Wheel Assembly with Brake
11. Rear Wheel Support Assembly
12. Fixed Wheel Assembly with Brake
13. 25kg Olympic Weight Plate
14. M12x30mm Bolt +M12 Hex nut
15. Sword Pin
16. M10 x 25mm Bolt +M10 Hex nut (Nyloc) + 2 x M10 Washersx nut (Nyloc) + 2 x M10 Washers

**E Markings and Conformity**

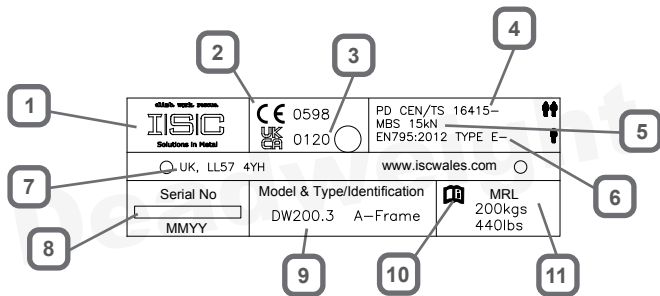

**[E] Markings and Conformity**

1. Manufacturer Logo
2. Notified Body Number (CE)
3. UKCA Notified Body Number (UKCA)
4. PD CEN/TS 16415: 2013 – Recommendations for anchor devices for use by more than one
5. 15kN (3372lbf) in accordance with IRATA ICoP and other leading industry guidance.
6. Approved to EN795:2012 Type E Single -person use, UKCA Certification PPE Regulation 2016/425 (as retained in UK law and amended)
7. Manufacturer Location
8. Serial Number
9. Model Identification
10. Read User Instruction Manual
11. Maximum Rated Load

## F Assembly

1

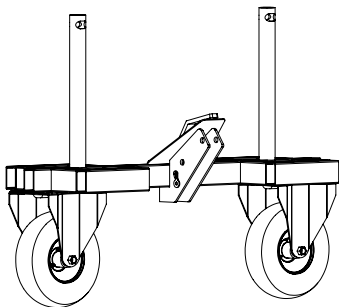

2

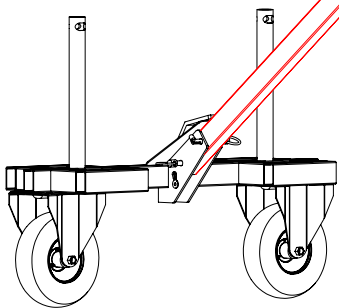

3

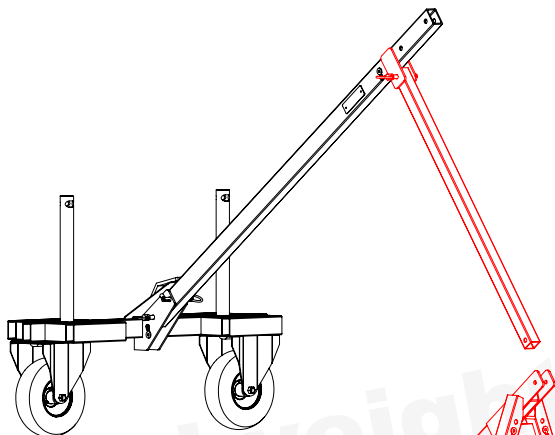

4

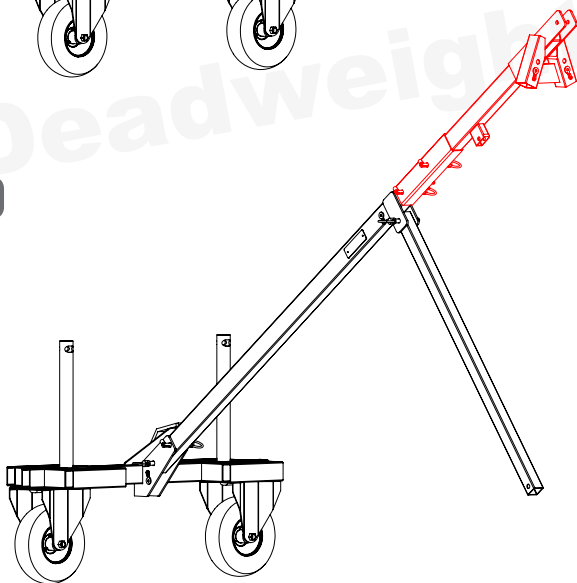

5

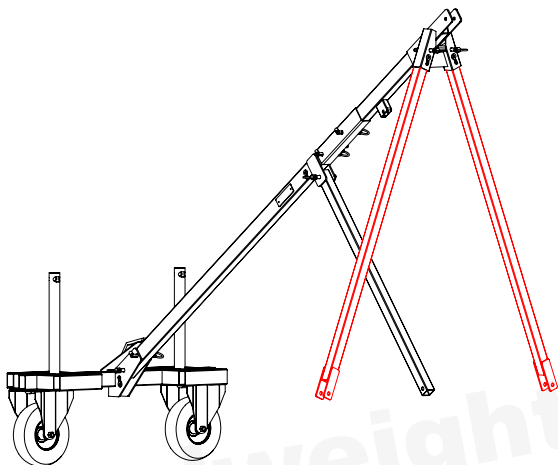

6

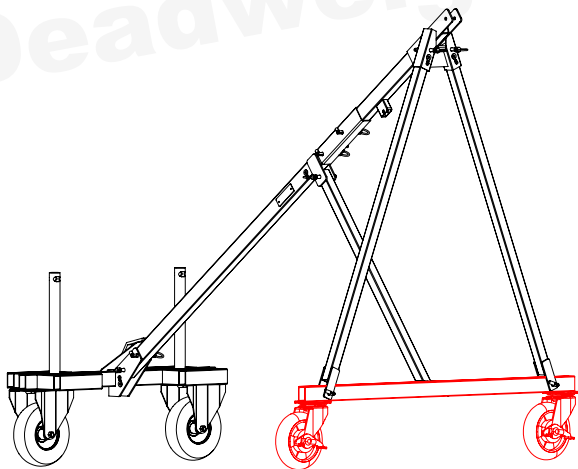

7

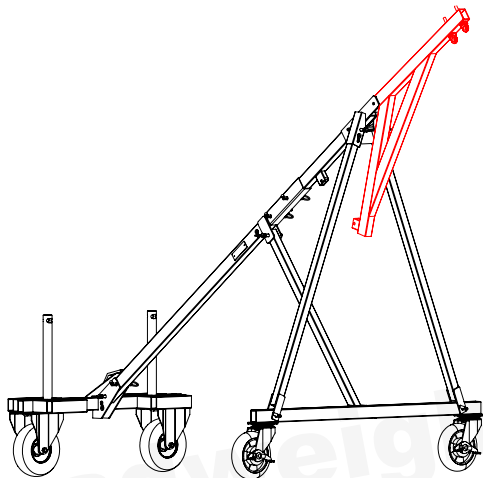

8

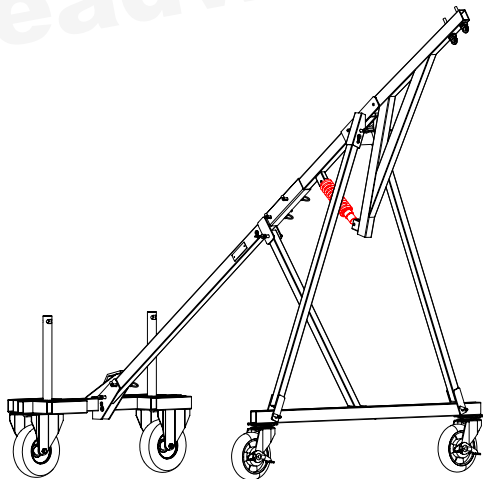

9

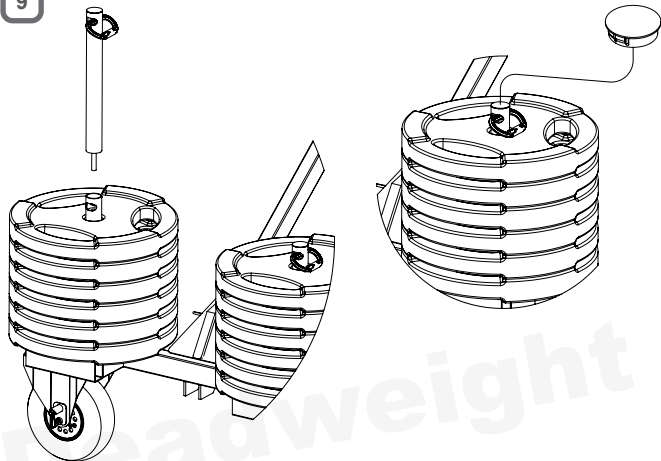

Mount the weights on the weight locator pole and clip a karabiner through the captivation hole, on the weight-mount pole. Alternatively, a padlock can be used, in order to prevent tampering of the device, during use.

The DW200.3 must always be used with a full set of weights (set = 12 x 25kg Olympic Weight discs). Each weight-mount pole should hold equal weight (6 x 25kg Olympic weights per pole).

Olympic weights can vary in depth. If your Olympic weights are too deep to use on the existing weight-mount poles, a pole-extension kit (sold separately) can be fitted.

To fit the extension pole:

1. Remove the plastic cap from the weight-mount pole on the device, to reveal a threaded hole.
2. Screw the threaded bar of the extension pole, in to the threaded hole.
3. Insert the plastic cap in to the top of the extension pole, to prevent ingress of water/debris.
4. Mount weights on to pole and secure karabiner/padlock through the captivation hole, at the top of the extension pole.



**[F] Assembly**

1. Attach [12] x2 to [11] using [14]
2. Attach [8] to [11] using [15] x2
3. Attach [5] to [8] using [15] x1
4. Attach [3] to [8] using [15] x2
5. Attach [6] x2 to [3] using [15] x2
6. Attach [10] x2 to [9] then attach [9] to [6] using [15] x2
7. Attach [2] to [3] using M12 80mm Socket cap head Screw + M12 nut (Nyloc) + 2 x M12 Washers
8. Attach [4] between [2] using 2 x M12 45mm Socket cap head screws + 2 x M12 nut (Nyloc) + 4 x M12 washers
9. Insert [13] x12 into [17]
10. Weight-locator Extension Pole (x2) with end caps (sold separately)

**[G] Technical Information**

1	30Nm / 20.65lbf
2	30Nm / 20.65lbf
3	2.07 bar / 30 PSI
4	400mm / 15.7"
5	600mm / 23.6"
6	70mm (200kg) / 2 <sup>3/4</sup> " (440lbs)
7	390kg (860lbs)

8

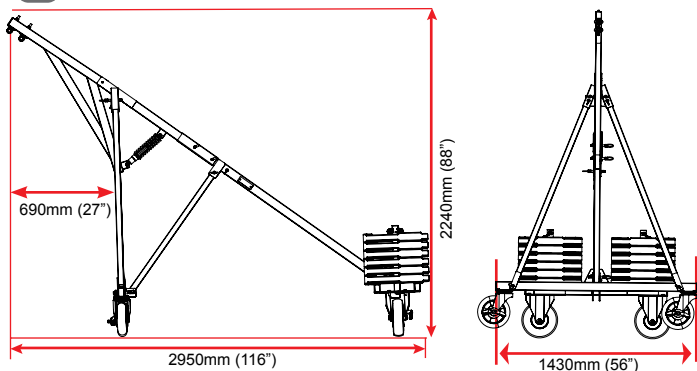

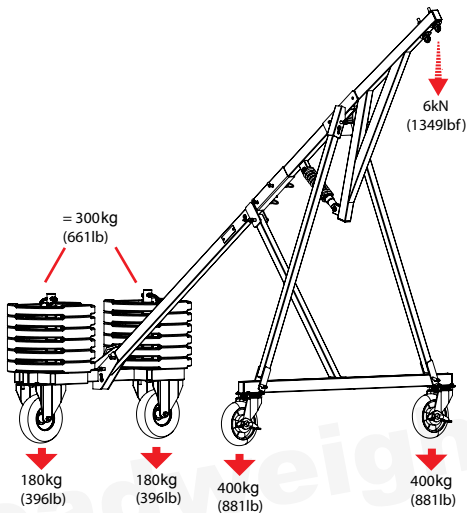

### [G] Technical Information

1. Anchor Point bolt torque setting
2. Wheel attachment bolt torque setting
3. Inflation pressures for tyres
4. Minimum distance for positioning from an edge
5. Maximum distance for positioning from an edge
6. Maximum deflection is  $0.07\text{m}$  ( $200\text{kg}$ )
7. Total Unit Weight
8. Dimensions
9. Point Loading

**Pre-Use Inspection**

1. Eyebolts: Ensure all eyebolts are securely attached
2. PPE Discs are present and in date
3. Weights: Ensure all weights are in place and secure
4. Sword Pins: Ensure all sword pins are in place and secure
5. Wheels: Ensure all wheels are secure, functioning and correctly inflated

**Thorough Inspection**

1. The Deadweight should be periodically inspected by a competent person in line with local and current legislation. The PPE discs located at the Anchor points [1] should also be replaced by the competent person at the same time and marked with next inspection date
2. In the event of a fall the unit must be withdrawn from use and inspected. It should not be put back into service until signed off by a competent person.
3. If any irregularities are found, then parts may be replaced or the unit should be retired
  - Dents or loss of section
  - Missing weights
  - Damaged eye bolts
  - Damaged welds
  - Damaged or loose wheels
  - Defective shock absorber

**Care and Maintenance**

1. The Deadweight is finished with a powder coating, this will chip over time so it is recommended that any exposed metal is kept rust free and touched up with a weather resistant, metal paint. It is recommended that all working parts are lubricated on a periodic basis with a suitable lubricant such as a light oil. It is recommended that the Deadweight is stored under cover at night and in the event that it becomes wet, it is dried and stored in a well-ventilated area away from direct heat.
2. The product should be stored in a clean, dry environment free from corrosive or chemical substances. Care should be taken to protect the product against damage during transportation.

**Repair and Servicing**

The end user may only carry out repair / replacement to wheels and sword pins

1. Wheel Replacement: Remove bolts and washers. Replace the wheel(s) and reattach using new bolts
2. Sword pin replacement: Prise open Darlaston (chain retainer) Washer with a flat headed screwdriver. Insert chainlink of new sword pin and close Darlaston Washer with a soft-faced hammer

**Puncture-proof Solid Tyres**

Flat-spots may appear on solid tyres, when loaded with weight for prolonged periods of time. When not in use, it is recommended that the device is stored without weights, in order to limit flat-spotting of solid tyres. The flat-spotting will not affect the function of the DW200.3 Anchor (aside from some rocking of the wheel, as it is rotated) and over time, once the weight is removed, the flat-spot area will revert to its normal shape.



**Product Record Details**

- 1 Item**
- 2 Serial Number.**
- 3 Year of manufacture**
- 4 Purchased from**
- 5 Purchase date.**
- 6 Name of Manufacturer**
- 7 Date of first use.**
- 8 Inspection date.**
- 9 Reason (periodic examination (E) or repair (R)).**
- 10 Conform.**
- 11 Comments.**
- 12 Signature.**

# Approvals

## Regulation (EU) 2016/425

Body responsible for production monitoring and inspection (Module D)

### Notified Body:

SGS Fimko Oy (0598)

Takomotie 8

FI-00380 Helsinki

Finland

## Regulation (EU) 2016/425 using EN795:2012

Body having carried out the CE type test (Module B)

SATRA Technology Europe Ltd. (2777),

Bracetown Business Park,

Clonee,

Dublin,

D15 YN2P.

Ireland

UKCA Certification UK PPE Regulation 2016/425 (as retained in UK law and amended).

UK  
CA 0120

Module D - Production monitoring and inspection (Ongoing conformity)

Module B - Product type test examination (Type Approval)

### Approved Body (Module D):

SGS United Kingdom Ltd (0120),

Rossmore Business Park

Ellesmere Port, Cheshire

CH65 3EN

U.K.

### Approved Body (Module B):

SATRA Technology Centre (0321),

Wyndham Way, Telford Way,

Kettering

Northamptonshire

NN16 8SD

U.K.

Deadweight

# Deadweight



Stay up to date with ISC e-mail alerts!

Scan the QR Code with your Smartphone to register for ISC e-mail Alerts. We will email you from time to time with news of new products, product updates and other news features which are relevant to your chosen industry.