

Powered Ascending Device

ACE-22

Operation Manual

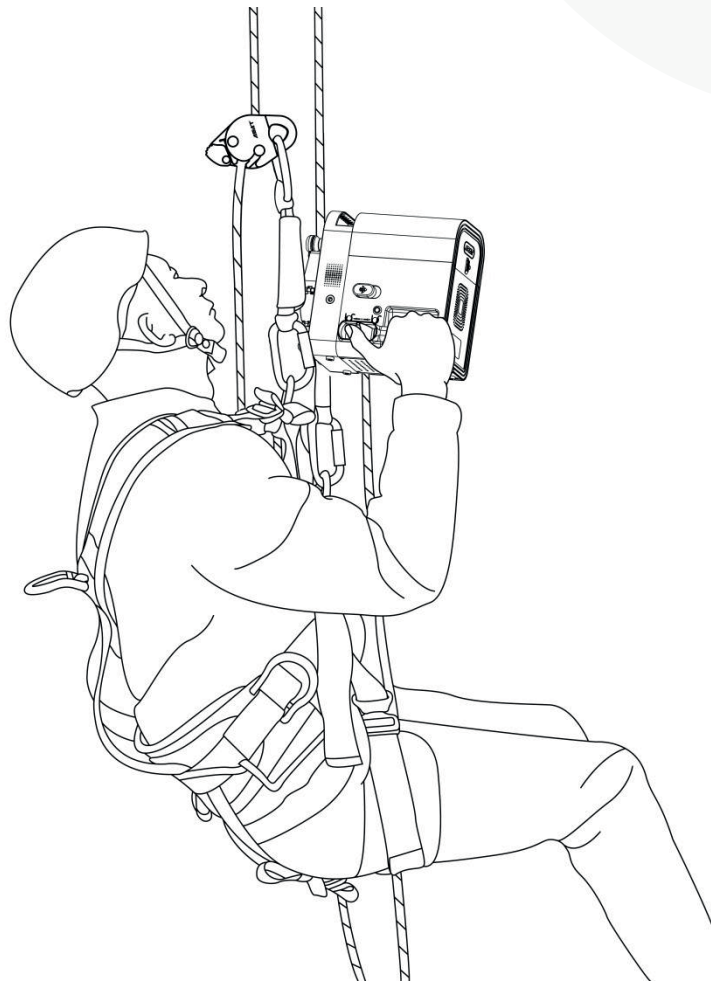

Distributed in UK, EU and MENA by
At Height Ltd.



Contents

1 Safety precaution	3
2 Functions	3
3 Training	5
4 Description	6
5 Operation	14
6 Associated equipment	19
7 Check and inspection	20
8 Storage, Transportation, Cleaning and Thorough Examination	20
9 Service life	21
10 Marking	21
11 Troubleshooting	23
12、 Annual Inspection Record Sheet	24

1、 Safety precaution

WARNING:

The Powered Ascending Device ACE-22(hereinafter referred to as 'the device') shall only be used by the trained persons who possess relevant safety knowledge. The users must verify that the adopted PPE and accessories are compatible with the device.

The users must read and fully understand the relevant operation instructions provided by ASAT. Failure to follow the instructions may result in serious injury or death.

The device can be used for man-riding access and material transportation along the vertical, horizontal or inclined ropes.

Before each use, the user must check the device to verify that it is in normal working condition.

Before each use, the user must verify that all markings on the device are complete and legible. If any query, please contact ASAT customer service or its authorized agencies.

Never use the device in explosive environment.

Do not allow the device to withstand dynamic loads during operation.

Use only the original parts of the device.

Charging the device battery by other chargers instead of the original one may cause damage of the battery, even explosion.

Maintenance of the device shall be performed by competent persons, who have been trained and certified by ASAT.

The anchor points used to connect to the device must be in accordance with EN795 or ANSI/ASSE Z359.15:2014.

Do not contact the ropes in conjunction with the device to sharp edges, rough surfaces, corrosive substances or fire.

Conduct the risk assessment and prepare the relevant rescue plan before each use.

The dedicated ropes used for the device model ACE-22 must be those provided by ASAT or verified in accordance with EN1891 by a competent person.

The device and its associated equipment must be inspected annually.

2、 Functions

2.1 Application

Used for single person individually: the user carrying necessary equipment can access the places along the dedicated rope at a specified speed by means of the device, where are difficult or impossible to access by other manners.

Emergency rescue: The device model ACE-22 can be used for rescue operation. The user carrying an incapacitated person can transfer to a safety place along the dedicated rope set up at a specified speed by means of the device.

Note: The total load carried by the device in rescue process shall not exceed the working load limit of the device, and the travelling speed of the device shall be slow.

Material transportation: the user can operate the device by remote control to transport tools and materials along the dedicated rope set up to the designated places.

2.2 Operation mode

Ascending and descending vertically: Operate the device ascending and descending vertically along the dedicated rope. A single working rope system can be used for material transportation, operated by remote control. In addition to the working rope, the safety rope, on which a fall arrester is attached, must be set up for manual operation.

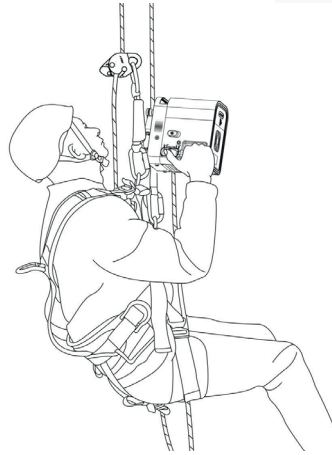

Traversing horizontally: Operate the device traversing along the working rope between two places at a small height difference and a certain horizontal distance. In addition to the working rope, another rope must be set up as the safety rope. The safety rope is attached with a pulley and a lanyard which connects with the safety harness of the user. During the operation, the lanyard attached to the safety ropes should keep slack and do not withstand any load in order to avoid affecting the running direction and operation state of the device along the working rope. In emergency, the user can perform a task using the working rope only without the safety rope in condition of that he is experienced to ensure his own safety.



Traversing inclinedly: Operate the device traversing along the working rope between two places at a certain height difference and certain horizontal distance. In addition to the working rope, another rope must be set up as the safety rope. The safety rope is attached with a fall arrester and a lanyard which connects with the attachment point of the safety harness of the user. During the operation, the lanyard connected with the fall arrester should keep slack and do not withstand

any load in order to avoid affecting the running direction and operation state of the device along the working rope. In emergency, the user can perform a task using the working rope only without the safety rope in condition of that he is experienced to ensure his own safety.

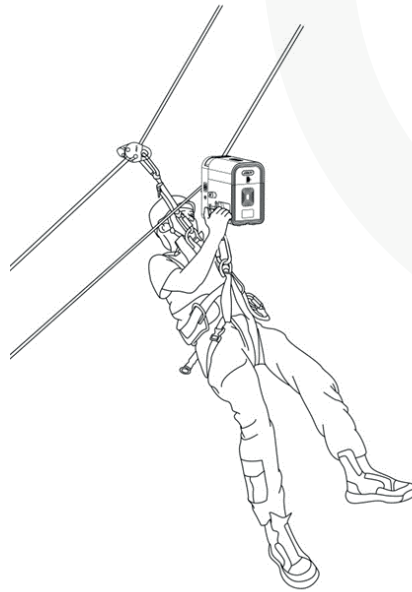

Note: During the process of traversing horizontally or vertically, the angle of the working rope at the position of the device shall be less than 150°.

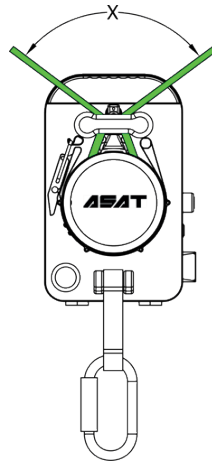

3、 Training

Users must have received the training from ASAT or an agency authorized by ASAT and obtained the certificate before using the device.

The training course is divided in two parts:

3.1 Basic knowledge and skills for rope access:

3.1.1. Operation and inspection of the device: through the training, users shall operate, inspect and maintain the device correctly.

3.1.2. Work safety: through the training, users shall comprehend the necessary safety management plans, relevant policies, work permit and work areas planning, and can conduct relevant Job Safety Analysis.

3.1.3. Knotting: through the training, users can make knots listed as follows independently and

comprehend the application, strength and limit of these knots :

- 3.1.3.1 Knots at anchor points: such as figure of eight, figure of nine.
- 3.1.3.2 Connecting knots: double fishermen, square knot.
- 3.1.3.3 Middle knots: butterfly knot.
- 3.1.4. Application of double rope system and associated equipment:
 - 3.1.4. 1. Use of descenders
 - 3.1.4. 2. Use of ascenders
 - 3.1.4. 3. Conversion from ascending to descending (system conversion)
 - 3.1.4. 4. Use of work seat
 - 3.1.4. 5. Passing through knots
- 3.1.5. Set up anchor points

3.2. Operation of the device

- 3.2.1. Check before each use.
- 3.2.2. Ascending and descending vertically.
- 3.2.3. Traversing horizontally.
- 3.2.4. Traversing inclinedly.
- 3.2.5. Identification and resolution of simple technical problems.
- 3.2.6. Maintenance and service of the device.

4. Description

4.1 Device composition :

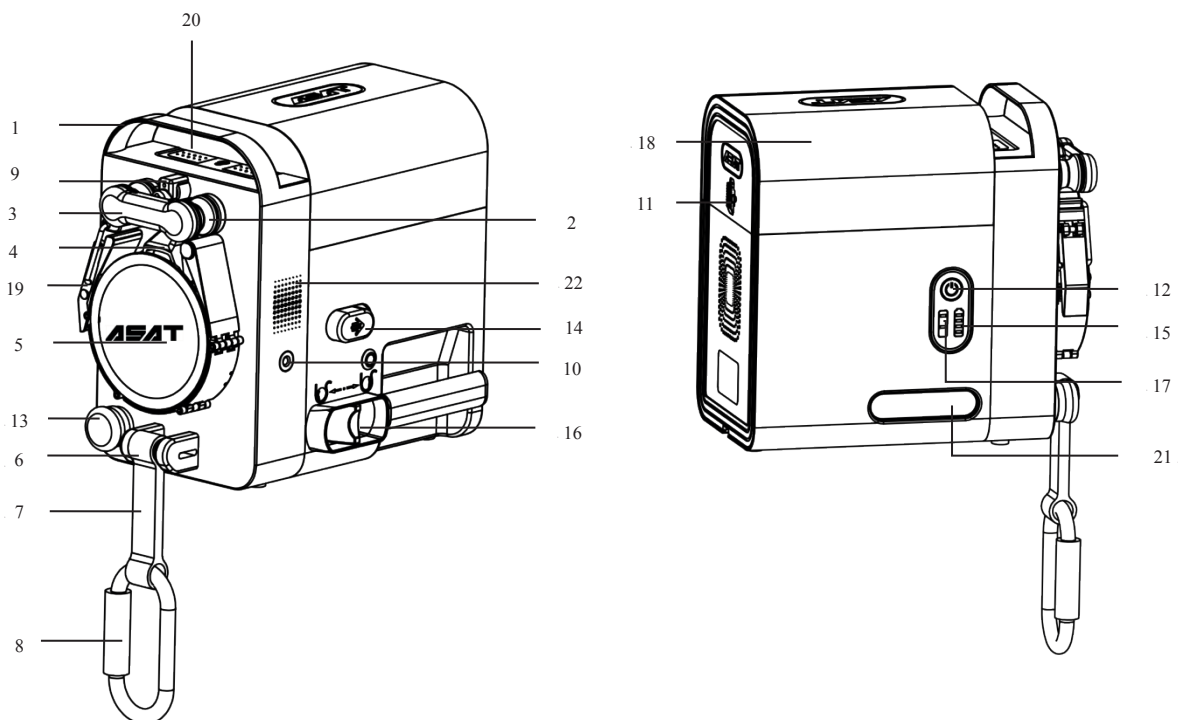

4.2 Components.

No.	Item	No.	Item
1	Handle	12	Power button
2	Rope guide pulley	13	Emergency stop button
3	U-shaped fender	14	Manual descent lever
4	Rope separator	15	Battery level indicator light (LED)
5	Rope sheave	16	Speed/direction thumb shifter
6	Load bearing rod	17	Warning indicator lights (motor temperature warning indicator light- T, motion warning indicator light - M)
7	Lanyard	18	Battery
8	Carabiner	19	Hinged steel band
9	Guide block	20	Battery lock
10	Intercom microphone	21	Hidden antenna
11	Battery secondary lock	22	Intercom loudspeaker

4.3 Technical parameters

Specifications	ACE-22
Rope	Dedicated static rope: φ11 mm in accordance with EN1891 A
Operation mode	Ascending and descending vertically/ traversing horizontally/ traversing inclinedly
Rated working load	140 kg
Working load limit	180 kg
Ascending speed	0-30m/min 140 kg (Stepless speed regulation)
Traversing speed	0-30m/min 140 kg (Stepless speed regulation)
Descending speed	0-40m/min 140kg (Stepless speed regulation)
Travel capacity of ascending and descending alternatively	400m/120 kg
Travel capacity of ascending continuously	160 m/120 kg
Charging time	< 1 hour
Operating temperature range	-20 ~ +60
Overheat protection	Yes
Device weight (incl. battery)	10.5 kg
Dimension	26×16×24 cm
Ingress Protection	IP 54

Remote control range (L)	0-150m (open space)
Manual descent	Yes
Intercom	Yes

4.4 Main components:

4.4.1 Components of rope sheave assembly

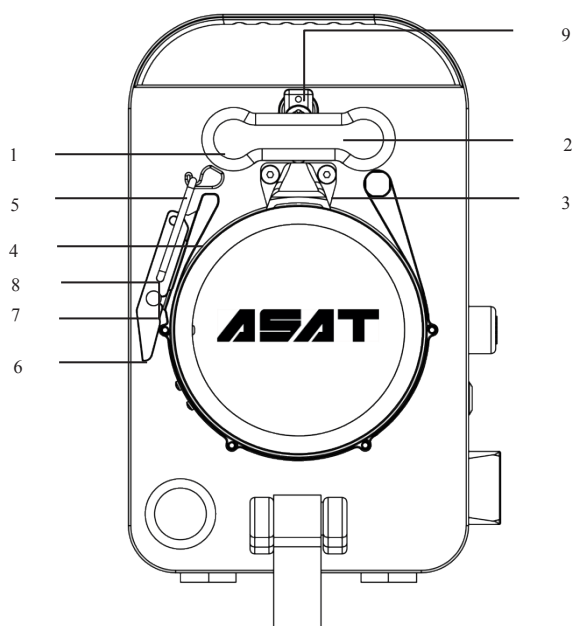

- 1- U-shaped fender
- 2- Rope guide pulley
- 3- Rope separator
- 4- Hinged steel band
- 5- Hook of hinged steel band
- 6- Lock handle of hinged steel band
- 7- Self-lock slot
- 8- Self-lock knob
- 9- Guide block

4.4.2 Control panel button, display and operation

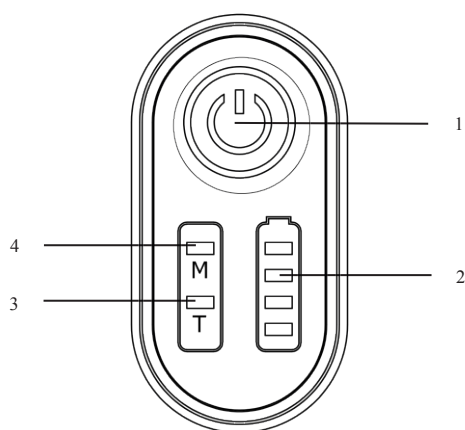

- 1- Power button
- 2- Battery level indicator light
- 3- Warning indicator light T
- 4- Warning indicator light M

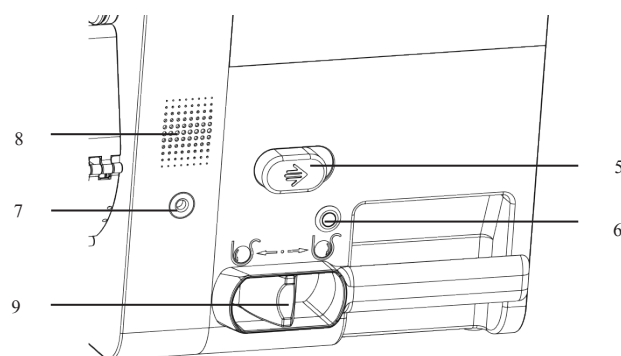

- 5- Manual descent lever
- 6-PTT intercom button
- 7-Microphone
- 8-Loudspeaker
- 9- Thumb shifter

4.4.2.1 : Power button:

In case of shutdown, when power button is pressed down, the device will be energized and process self-test accompanying 'beeps' issued from the motor. Then the battery level indicator lights are lit on and the device is ready for normal operation.

Under normal mode, after the power button is pressed down and hold for 3 seconds and then released, all indicator lights turn off and the device is shut down.

Battery level indicator lights: The lights consist of four LEDs. Counted from the top, the first and second are green colored, the third yellow colored and the fourth red colored. Each LED indicates 25% of the battery level.

LED indicator lights	Residual battery level
Two green, one yellow and one red	75-100%
One green, one yellow and one red	50-75%
One yellow and one red	25-50%
One red	0-25%

Note: When only one red LED is lit on, charge the battery as soon as possible.

Note: At the ambient temperature below zero, the battery level is indicated inaccurately. For example, when two LEDs (one red and one yellow) are lit on, the residual battery level may be only about 15% of the total battery level instead of 50% as indicated at an ambient temperature below zero. When the device is heavily loaded, the consumption of battery level will accelerate.

Note: When the emergency button is pressed down, only one red LED is lit on the battery level indicator lights.

4.4.2.3 Warning indicator light T:

When the warning indicator light T flickers, it means that the motor is already overheated. If the device is operated continuously in the case, the motor temperature will increase even higher and the built-in controller will forcedly shut down the device.

In the case, the user can press down the emergency stop button, turn off the power and then manually descend to the ground for a rest. After taking rest a period of time for motor cooling until the warning indicator light T is off, the device will resume its normal working condition.

4.4.2.4 Motion warning indicator light M:

When the warning indicator light M flickers slowly, it means that running direction of the motor detected is contrary to that intended and the built-in controller will forcedly stop the motion of the motor.

When the warning indicator light M flickers fast, it means that the running speed of the motor is out of control and the built-in controller will forcedly stop the motion of the motor.

When the warning indicator light M flickers 2 on and 1 off constantly, it means that the battery voltage is too high so that the device stops operation. The case usually occurs during descent process when the battery is just fully charged.

When the motion warning light is steady lit on, it means that a motion command is issued but the motor does not run because the built-in controller forcedly stops the motion of the motor.

In case that one of above mentioned three warnings occurs, reset the device to eliminate the warning and resume its normal working condition. There are two methods to reset the device: 1) press down the emergency stop button, wait for about 3 seconds, and then pull it up; 2) press and hold any button on remote control for 3 seconds and then release it.

If the fault warning still cannot be eliminated after the reset, turn off the device, descend manually to the ground and then contact the customer service of ASAT for repair.

4.4.3 : Emergency stop button

In any case, the device shall stop immediately and engage on the working rope when the emergency stop button is pressed down.



4.4.4 Battery and charger

4.4.4.1 Battery

4.4.4.1.1 The device is fitted with a detachable high-capacity lithium battery.

4.4.4.1.2 Battery protection

The battery system is equipped with monitoring functions to protect the battery circuit, which include current output protection, overvoltage and overcurrent charging protection, and high temperature output cutoff protection.

Current output protection: when the device is overloaded or the battery output is short circuit, which causes too large output current, the battery system will automatically stop current output to protect the battery and the drive control system;

Low voltage protection: when the battery level is low, which cause the battery voltage is lowered to certain extent, the current output will be cut off automatically;

High temperature protection: when the battery temperature is higher than 65 ° C (e.g., running of the device for a long time), the current output will be cut off automatically.

Overvoltage and overcurrent charging protection: when the charging voltage or current to the battery is higher than the rated values during charging process, the input current will be cut off or limited by the battery system automatically for battery protection.

The battery can be charged at any time and has no memory effect, which may result in battery capacity reduction.

4.4.4.1.3 The battery capacity will reduce along with the running time. Its capacity will reduce for every 10,000 m of accumulated running distance (with the rated load); the battery should be discarded after 100,000 m of accumulated running distance (with the rated load).

4.4.4.1.4 The service life of the battery is approx. 3-4 years.

Note: Charge the run-down battery as soon as possible to prevent its failure owing to long time in uncharged state.

In storage the battery shall be checked and recharged quarterly.

4.4.4.2 Battery Mounting and removal :

4.4.4.2.1 Battery removal: At first, press down the secondary lock button and push the lock catch

upward to unlock the secondary lock. Then, press the two battery locks on the top by the left hand and pull the battery out by the right hand to remove the battery, as shown in the pictures below.

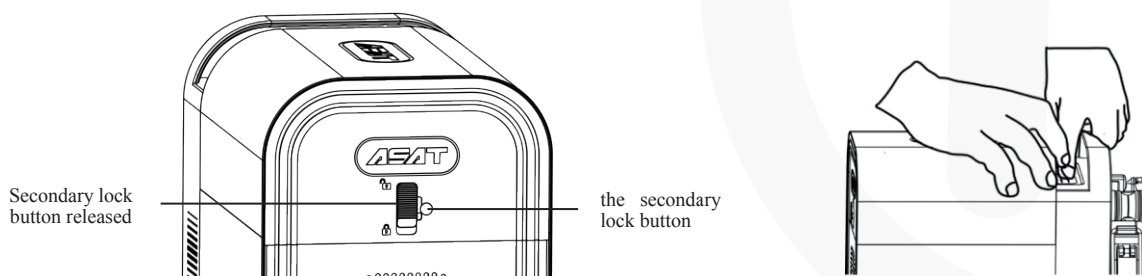

4.4.4.2.2 Battery mounting: Insert the slots on the bottom surface of the battery into the tracks on the top surface of the device correctly and push the battery forward until it contacts with the side surface of the device. Verify that the battery locks are locked and the battery cannot be pulled out. Then press down the secondary lock button to let the lock catch slide downward automatically until the battery is locked completely, as shown in the pictures below.

Note: Before operation, make sure that the battery is mounted reliably.

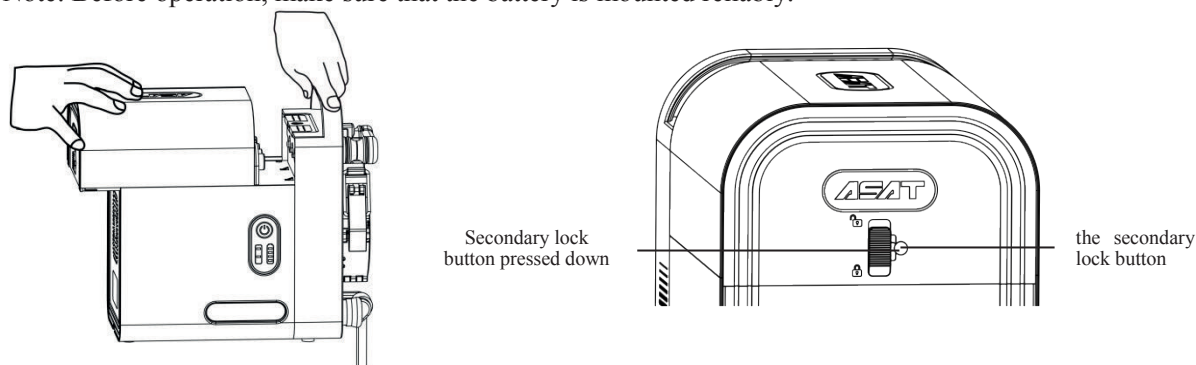

4.4.4.3 Charger

A dedicated quick charge is provided with the device. It can fully charge the battery in about 1 hour. When the charger indicator light is green lit on, it means that battery is charged 80% of its capacity. At the time, charging of additional 20 minutes is needed to make the battery fully charged. Verify the power voltage for the charger before charging the battery. Adjust the charger to 220V or 110V to the correct power supply(see below).

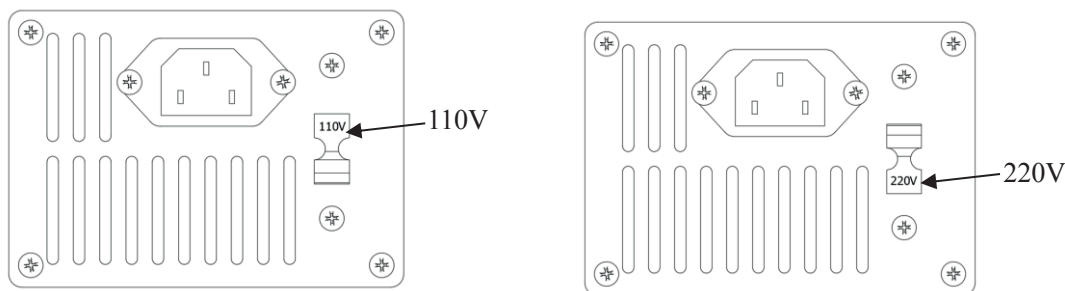

4.4.4.4 Charging

4.4.4.4.1 Remove the battery from the device. Verify that the charger electrodes correspond with the battery electrodes correctly, as shown in the picture below.

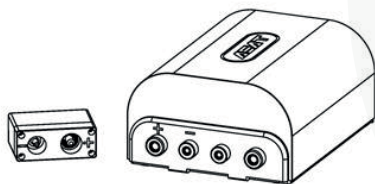

4.4.4.4.2 Insert the charger output plug into the battery charging socket, as shown in the picture below.

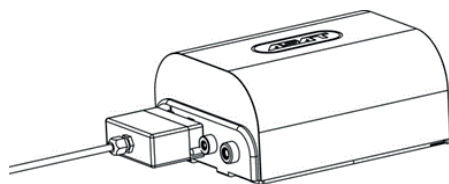

4.4.4.4.3 Connect the charger to the power supply to start charging.

4.4.4.4.4 The charging consists of two processes: constant-current charging and constant-voltage charging.

During constant-current charging, charger indicator light is red lit on; When the light turns to green lit, it means that battery is charged 80% of its capacity. At the time it needs to charge the battery in the process of constant voltage charging for additional 20 minutes to make it fully charged.

4.4.4.4.5 During the process of charging, the integrated fan is running to dissipate heat.

Note: If the charger is not connected with the power supply or the charger switch is not turned on, but the battery is still connected with the charger, the battery will gradually discharge until it cannot be recharged any longer.

Danger! In order to prevent accident, battery charging is forbidden in unattended condition.

4.4.5 Remote control/intercom

Note: Remote control function and intercom function cannot be used at the same time.

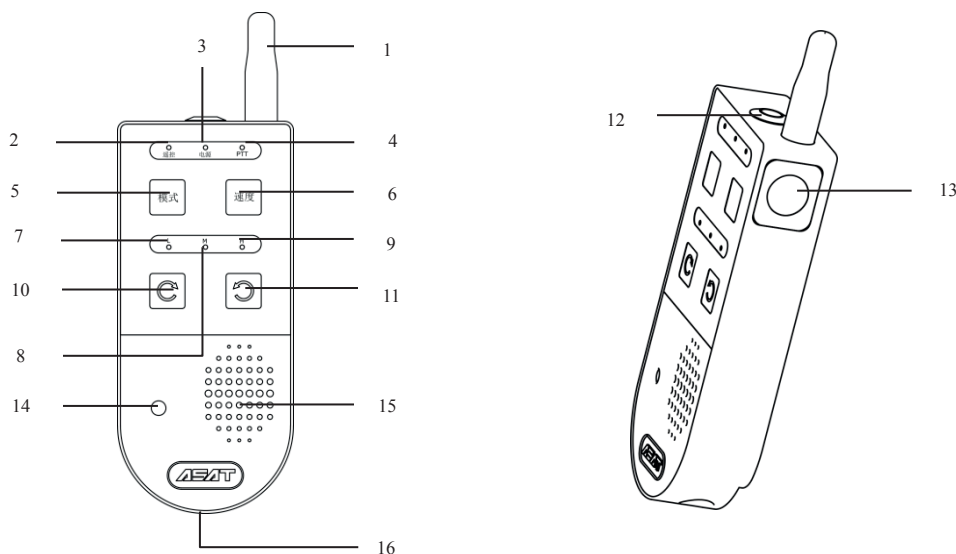

No.	Item	No.	Item
1	Antenna	2	Remote control indicator light
3	Power indicator light	4	Intercom indicator light (PTT)
5	Mode conversion button	6	Speed selection button
7	Low speed indicator light	8	intermediate speed indicator light
9	High speed indicator light	10	Clockwise running button
11	Anticlockwise running button	12	Power button
13	Intercom button	14	Intercom microphone
15	Intercom loudspeaker	16	Charge interface

4.4.5.1 Charging remote control/intercom

When the remote control/intercom distance becomes obviously shorter, it means that the remote control/intercom battery is low and it needs to be charged.

Note: The remote control/intercom charger provided is dedicated for the battery, which cannot be replaced by other chargers.

4.4.5.2 Intercom function

When the power button is switched on, the power indicator light flickers, defaulting the mode as intercom. When the intercom indicator light (PTT) is steadily lit on, the remote control mode and intercom mode can be converted by pressing mode conversion button.

In remote control mode, the remote control indicator light flickers; in intercom mode, the intercom indicator light (PTT) is steadily lit on.

In intercom mode, when the person holding the remote control/intercom presses down the intercom button to speak to the intercom microphone, his voice will be heard from the loudspeaker of the device. The person shall release the intercom button when his speak is over.

If the remote control/intercom is in intercom mode, when the person with the device presses down the PTT intercom button on the device to speak to the device microphone, his voice will be heard from the loudspeaker of the remote control/intercom. If the remote control/intercom is in remote control mode, the voice transmitted from the device cannot be heard.

Note: the talk through the intercom can only be carried out when the operation of the device is stopped, in order to prevent the danger caused by the device motion;

4.4.5.3 Remote control function

In remote control mode, the running direction of the device can be controlled by the anticlockwise running button and clockwise running button.

Recommendation of rope rigging for the device: facing the rope sheave, if the rope end at the left side of the rope sheave is attached to the upper anchor point and the rope end at the right side of the rope sheave is freely suspended, the device will ascend when the rope sheave turns anticlockwise, and descend when the rope sheave turns clockwise.

Note: The equipment has a certain response delay to the signal of the remote control. In order to avoid accidents, issue the signal of remote control a little bit earlier to offset delay effect.

The running speed of the device can be regulated by the speed selection button. Select a running speed between 'Intermediate speed' and 'Low speed' before operation.

The number of speed indicators lights lit on indicates the running speed of the device, one for low speed, two for intermediate speed.

Before using the remote control function for rescue, a test operation must be carried out in a safe

place.

Speed switching button controls the running speed, please select the running speed before operation. If the speed indicator L is on, the remote control will control the device to operate at low speed; if the speed indicator M is on, the remote control will control the device to operate at medium speed;

Model ACE-22 have only two options of low speed and medium speed.

Before using the remote control function for rescue, a test run must be conducted in a safe environment.

4.4.5.4 During the remote control operation, if the motion warning indicator light M is steady lit on or flickers, the device cannot work normally. In the case, press down and hold any button on the remote control for 3 seconds to reset the device. After reset successfully, the device will resume its normal working condition.

4.4.5.5 Remote control/intercom distance

Remote control/intercom distance is 0-150 m. Each device is matched correspondingly with a remote control/intercom. The coded identification between the device and remote control/intercom is tested in the factory.

To operate the device by matched remote control/intercom may interfere the operation of the other devices in close proximity. Avoid such case or turn off the other devices is necessary.

Note: There should be a good visibility between remote control/intercom and the device to achieve good remote control effect.

4.4.6 Overload and overheat protection

4.4.6.1 Overload is strictly prohibited for the device.

4.4.6.2 The temperature of the motor and battery will increase dramatically in case that the device carrying a heavy load runs continuously. When overheated, the device will issue warning or even shut down automatically to protect the safety of the device and user.

5、 Operation

Note: The associated safety rope system must be set up in case of non-emergency.

Note: There is the risk of falling objects when the user is working at heights; protective measures shall be taken to isolate the dangerous area in order to prevent the unauthorized personnel entering.

Note: The user working at heights must always keep his portable tools and equipment attached firmly with his safety harness.

5.1 Rope rigging

5.1.1 Working rope rigging

5.1.1.1 Press down the self-lock knob of the hinged steel band, lift up the lock handle of the hinged steel band to release the hinged steel band.

5.1.1.2 Make a loop on the rope, press down the guide block by one hand, and by the other hand pass the rope loop through the guide block and rope separator inside of the U-shaped fender, and reeve the rope on the rope sheave and tension it.

It is recommended to rigging the rope in such way that the rope end at the left side of the rope sheave is attached to the upper anchor point and the rope end at the right side of the rope sheave is freely

suspended. In the case, the device will ascend when the thumb shifter is pushed forward, and descend when the thumb shifter pushed backward

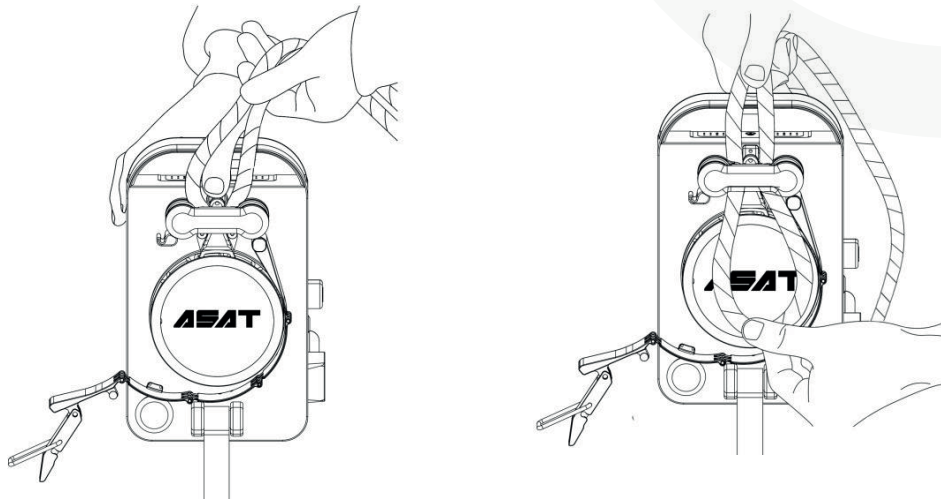

Note: Ascent or descent of the device depends on the turning direction of the rope sheave and rigging of the working rope.

5.1.1.3 Attach the hinged steel band to its hook, adjust it to the correct position and press down its lock handle.

If the rope is too stiff to press down the lock handle of the hinged steel band, turn on the device and operate it running in anticlockwise direction to drive the rope turning. At the time, take chance to press the hinged steel band and lock its handle easily.

Verify that the hinged steel band is locked firmly after its lock handle is pressed down.

Pull up the lock handle of the hinged steel band gently to ensure that it cannot be unlocked.

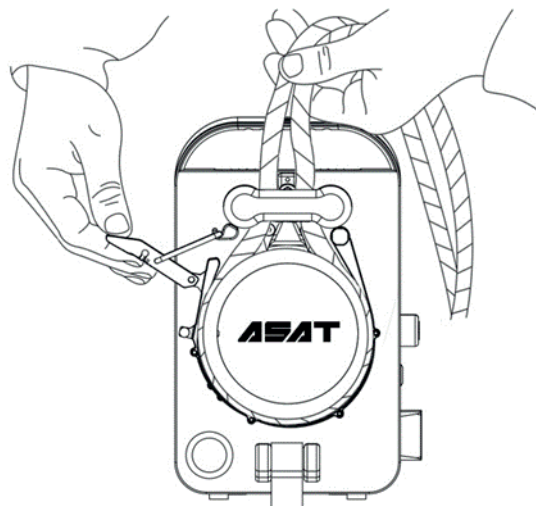

5.1.2 Set up of associate safety rope system: The associated safety rope system must be set up in case of non-emergency.

5.1.2.1 Attach the fall arrester onto the safety rope, connect it with the sternal attachment point of the full body harness.

Note: During traversing horizontally or inclinedly, the lanyard connected with the safety rope shall keep slack and have no significant pulling force to the device in order to avoid effecting the normal operation of the device, as shown in the figure:

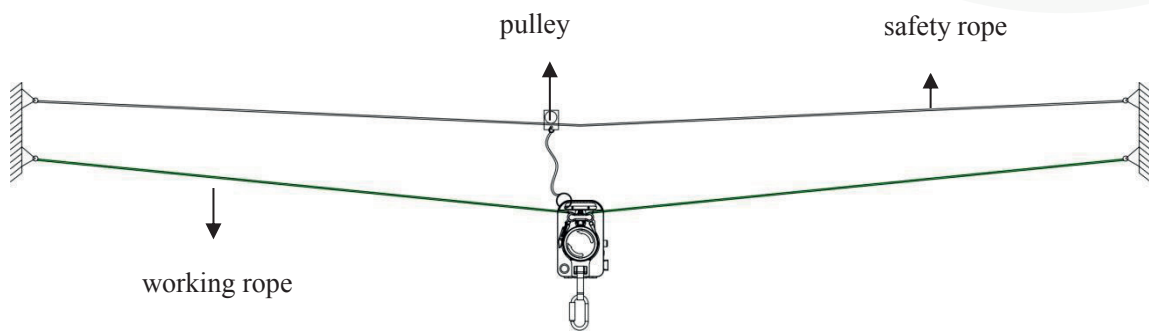

5.1.2.2 Connect the device carabiner with the ventral attachment point of user's harness.

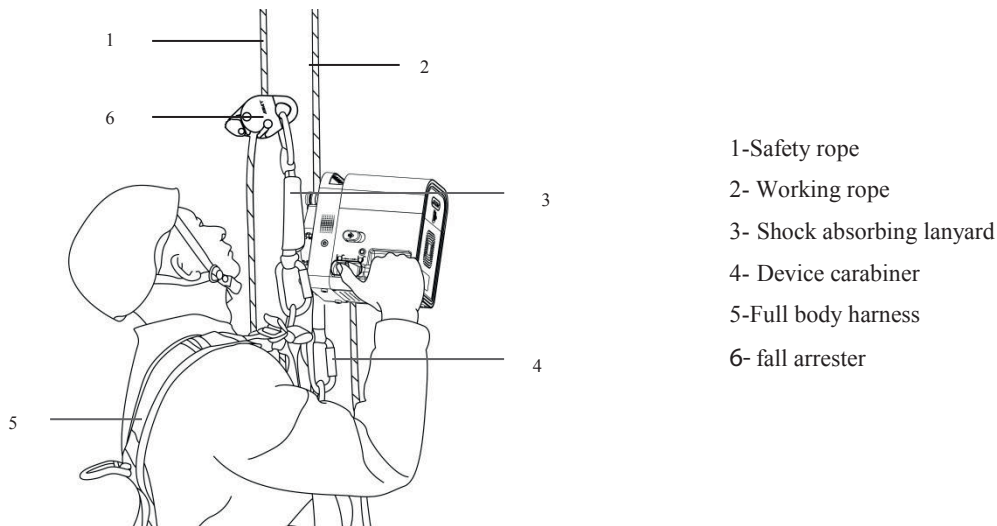

5.2 Running: Ascending, descending, traversing horizontally or inclinedly

Press down the power button to energize the device. The battery level indicator lights present the current battery level.

When used only by one person (light load) with sufficient battery level, the device can run at a high

speed; when used by carrying heavy load or with insufficient battery level, the device will be switched to run at a low speed automatically.

If the battery level is in fully charged state, a warning may issue during descending. In the case, descend at a low speed gradually.

5.2.1 When the thumb shifter is pulled forward, the rope sheave will turn anticlockwise. When the thumb shifter is pulled backward, the rope sheave will turn clockwise. The running direction of the device and turning direction of the rope sheave depends on the rigging of the working rope. The larger the angle of the thumb shifter pushed, the faster the running speed of the device.

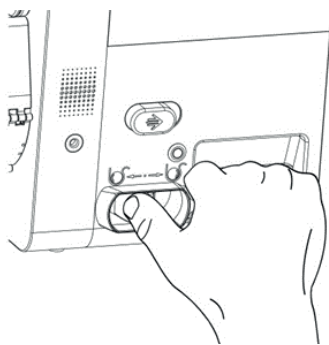

Note: In case of ascending or descending vertically, in order to relieve the twisting stress in the rope, start the device ascending off the ground and suspend for several seconds to release twisting stress in the rope. Then the subsequent running will become smooth.

Note: During the initial phase of operation, operate the device ascending off the ground and suspend for a while to adjust the body posture, and the positions of the rope, device and fall arrester properly.

Note: Control the running speed of the device less than the triggering speed of the fall arrester.

Note: The device will stop running as soon as the thumb shifter is released at any time.

Note: It is very dangerous to running the device on the twist working rope. Twisting of the working rope may result in the rotation of the user and tangle of the working and safety ropes during the running of the device.

Therefore, user must eliminate twisting of the rope before ascending.

Danger! Do not grasp the rope section above the device during ascending or the rope section below the device during descending. Do not grasp the rope section at the front along the running direction of the device during traversing. Otherwise, the hands of the user may be crushed.

5.3 Emergency stop

When the emergency stop button is pressed down, the device will stop running immediately and only one red battery indicator light is lit on. When the emergency stop button is pulled up to release, the battery level indicator lights will present normally and the device will resume the normal working condition.



Note: During working at heights, press down the emergency stop button to prevent maloperation.

Note: Before the device is powered off or on, press down the emergency stop button to prevent maloperation.

5.4 Manual descending

During ascending and descending vertically, if the battery is run-down or the device is out of order, the user can descend to the ground safely by the function of manual descending.

Manual descending steps :

5.4.1 Turn off the power.

5.4.2 Press down the emergency stop button.

5.4.3 Push the manual descent lever rightward to descend the device. The greater the pushing extent, the faster the descending speed.

5.4.5 Once the manual descent lever is released, it returns to its original position to stop descending.

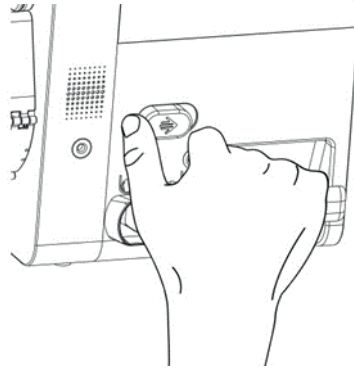

Note: Do not use manual descending function continuously over a long distance.

Note: Regulate the descending speed according to the actual situation. In order to ensure the safety of the user, the manual descending speed shall not be too fast.

Note: Manual descending may cause impairment to the driver and slowing down the descending speed may relieve the situation.

Danger!! In case the device is powered on and operated normally, if manual descending is required, it must to turn off the power, press down the emergency stop button, and then descend manually; otherwise not only the manual descending function is not available but also the device may be damaged.

5.5 Use of remote control/intercom

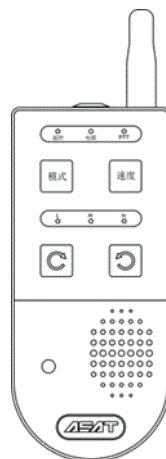

When the power button of the remote control/intercom is pressed down, the power indicator light flickers, which means that the remote control/intercom is in normal working state. When the operation mode is selected through the mode conversion button, either the remote control indicator light flickers or intercom indicator light is steadily lit on.

5.5.1 Remote control mode:

The running direction of the device shall be determined according to the rigging of the working rope and the turning direction of the rope sheave. When high speed, intermediate speed or low speed is selected by pressing the speed selection button, the corresponding speed indicator lights is lit on. Press the clockwise or counterclockwise running button to operate the device.

If the motion warning indicator light M is lit on, the device cannot operate normally.

In the case, press and hold any button on the remote control for 3 seconds and then release it to reset the device. After reset successfully, the device will resume its normal working condition.

Note: Each device is matched correspondingly with a remote control, which shall be verified before each use.

Note: Do not operate the device by remote control if the device cannot be observed during operation.

Note: Keep good visibility between the remote control and the device in order to reach the maximum remote-control distance. When the remote-control distance becomes shorter, check whether the battery level of remote control/intercom is low and charge the battery if necessary.

Note: If the operation of the device controlled by the remote control is unstable owing to the long distance between the device and the remote control, shorten the distance by approaching the device with the remote control immediately to prevent out of control to the device!

Note: when the device is operated by the matched remote control/intercom, turn off the other devices in close proximity to avoid interference to them;

5.5.2 Intercom Mode

In intercom mode, the person carrying the remote control/intercom can press down the intercom button to talk with the person working with the device. The person working with the device can press down the PTT intercom button on the device to talk with the person carrying the remote control/intercom.

The intercom is simplex system. At a time, only a person can talk and the other listen.

Intercom voice is not encrypted, the intercom on the remote control and the device can communicate with several other remote controls and devices.

Note: When talking through intercom, stop the device running and press down the emergency stop button!

6、 Associated equipment

6.1 Harness: The device can only be used in conjunction with the full-body harnesses in accordance with EN361 and EN813.

6.2 Anchor point: The anchor points connected with the device shall be in accordance with EN795 or ANSI/ASSE Z359.15:2014.

Selection of anchor points is crucial to safety. The anchor positions should keep the ropes away from sharp edges or subjects. If necessary, use the rope protectors provided by ASAT to protect the ropes.

6.3 Connecting parts:

The connecting parts as follows can be selected for use with the device:

Lanyards in accordance with EN354/EN795.

Work positioning lanyards in accordance with EN358.

Connectors in accordance with EN362

6.4 Rope

The dedicated ropes provided by ASAT for the device are recommended.

If other ropes are selected instead, the properties shall be verified by a competent person.

6.5 Associated safety system

The associated fall protection system must be set up in case of non-emergency.

7、 Check and inspection

7.1 Daily check :

7.1.1 The user, who has obtained a professional training, shall check the device before each use. The items to be verified are as follows:

7.1.1.1 Rope sheave and rope guide pulley: they are mounted firmly without bolt looseness; there is no excessive abrasion on the toothed groove of the rope sheave;

7.1.1.2 Hinged steel band assembly: There is no solder joint off on the assembly nor crack on the hook; the locking function is normal;

7.1.1.3 Guide block: There is no looseness, nor excessive abrasion; its compression and extension are flexible.

7.1.1.4 Rope separator: it is mounted firmly; there is no excessive abrasion.

7.1.1.5 Carabiner: there is no crack nor corrosion on it; the locking function is normal.

7.1.1.6 Device casing: there is no crack nor corrosion on it; there is no screw looseness.

7.1.1.7 The functions of operating buttons, speed/direction thumb shifter and remote control/intercom are normal;

7.1.1.8 The battery level for device and remote control/intercom is sufficient for the task.

7.1.2 Rope: verify the conditions of its surface layer, sewn ends and diameter are good enough to be used in conjunction with the device.

7.1.3 : Check of associated equipment.

7.1.4 Check record of the device in 12 months.

7.1.5 After each use, the device must be checked by a competent person to verify that no damage is found after the operation, and check result recorded.

7.1.6 Annual inspection and annual inspection record sheet

The device must be inspected in every 12 months by a competent person and the inspection result recorded.

Note! The inspection result of the device must be filled in Annual Inspection Record Sheet provided by ASAT.

Note! If any default endangering the safety is found, never use the device further and send it to a qualified agency of ASAT for repair.

7.2 The template of Annual Inspection Record Sheet is as annexed in Section 12.

8、 Storage, Transportation, Cleaning and Thorough Examination

8.1 Storage :

The device shall be packed in a box, which is light-proof, moisture-proof and chemical-proof, for storage and transportation.

The device shall be stored in the environment of normal temperature.

8.2 transportation :

For handling at work site, the user can carry the device by the handle on the device top.

For distance transportation, the device shall be packed properly.

Note: For long-term of storage, take the device out of the box and place it on a suitable storage rack.

8.3 Cleaning :

Clean the device regularly, and check the rope sheave, rope guide pulley, hinged steel band assembly, rope separator, guide block and carabiner for corrosion. Blow any residual rope scraps off the rope sheave, U-shaped fender, rope guide pulley, hinged steel band assembly, guide block and rope separator by a pneumatic blowing device. Lubricate required components.

8.4 Thorough Examination:

Danger!

If any abnormality, such as fault or defect, is found in any check or inspection, carry out a thorough examination to the device!

9、 Service life

The quick-wear parts of the device and their service life are listed as follows:

9.1. Rope sheave and rope guide pulley: they must be replaced if the abrasion loss is more than 1/5.

9.2 Battery:

Battery scrapping criteria: the battery must be scrapped if the device, carrying 120 kg of load and powered by the battery fully charged, can ascend and descend less than 100 m totally in circles of about 10 m. The battery used for 4 years must be tested in accordance with the criteria mentioned above to decide whether it shall be scrapped.

9.3 Rope sheave: the rope sheave must be replaced if a new rope of 11 mm diameter in accordance with EN1891A slips through the rope sheave when the device, carrying a load of about WLL, ascends in accelerated phase.

9.4 Hinged steel band assembly: the assembly must be replaced if any crack or excessive abrasion is found on it;

9.5 Rope

Note: The service life of the rope is closely related to the operating conditions.

The service life of the rope shall be greatly shortened if the device is used in severe conditions, such as in extreme temperature environment, in contact with chemicals, sharp edges or rough surfaces.

If any doubt to its property for safety, the rope must be replaced immediately.

The rope must be replaced every 5 years even under conditions of normal use and proper maintenance.

10、 Marking

10.1 Identification plate:

ASAT EXPERT IN PROTECTION		Power ascender		CE
Model	ACE-22	Weight	10.5kg(incl. battery)	
Size	26x16x24cm	Rated voltage	44.4VDC	
Rated power	1.5kW	Working load limit	180kg	
Textile rope	Φ11mm	Rated working load	140kg	
Speed	0~30m/min	Capacity	5.2Ah	
S/N	Production date			
SKYER(Beijing) Industry Technology Co., Ltd				

10.2 Sign on rope sheave



10.3 Sign of rope rigging and turning direction of rope sheave at thumb shifter

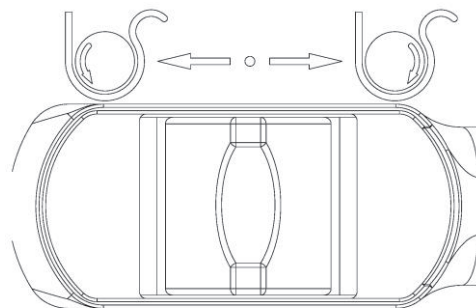

11、 Troubleshooting

If any problem found cannot be solved by referring this manual, please contact ASAT or its distributors.

Fault message	Possible cause and remedy
The device cannot be energized when the power button is pressed down.	The battery is run-down or damaged.
	The secondary lock does not lock properly
The device cannot ascend and descend after energized.	The emergency stop button is not released, the device is overloaded or motion warning indicator light M issues warning.
The remote control/intercom cannot operate of the device.	1、 There are obstacles between the remote control/intercom and the device.
	2、 The battery of the remote control/intercom is run-down.
	3、 The device is not powered on or the motion warning indicator light M issues warning..
	4、 The distance between the remote control/intercom and the device is too far.
	5、 The remote control/intercom does not match with the device.
	6、 The remote control/intercom or the device is damaged.
The device stops operation even with fully charged battery.	1、 The motor temperature is too high.
	2、 The battery is aged or failed.
The rope slips through the rope sheave.	1、 The rope is damaged.
	2、 The rope sheave is aged or worn.
	3、 The rope does match with the rope sheave.
Motion warning indicator light M flickers or is steady lit on	Reset the device. If the fault still cannot be eliminated contact ASAT customer service after descending manually.
Temperature warning indicator light T flickers or is steady lit on	The motor temperature is too high. Shut down the device for cooling.

12 Annual Inspection Record Sheet



ASAT powered ascending device annual inspection record sheet

Customer :		
Product name		
Model/Serial Number	Inspection site	Inspection date
No.	Inspection item	Result
1	Rope sheave and rope guide pulleys	
2	Hinged steel band assembly	
3	Guide block	
4	Rope separator	
5	Carabiner	
6	Device casing	
7	Buttons, battery level indicator light, speed/direction thumb shifter, remote control/intercom	
8	Fastening screw on rope sheave	
9	Battery	
10	Rope	
11	Others	
Inspection conclusion		
Inspected by (Signature)		

ASAT powered ascending device annual inspection record sheet

Customer :		
Product name		
Model/Serial Number	Inspection site	Inspection date
No.	Inspection item	Result
1	Rope sheave and rope guide pulleys	
2	Hinged steel band assembly	
3	Guide block	
4	Rope separator	
5	Carabiner	
6	Device casing	
7	Buttons, battery level indicator light, speed/direction thumb shifter, remote control/intercom	
8	Fastening screw on rope sheave	
9	Battery	
10	Rope	
11	Others	
Inspection conclusion		
Inspected by (Signature)		

ASAT powered ascending device annual inspection record sheet

Customer :		
Product name		
Model/Serial Number		Inspection site
		Inspection date
No.	Inspection item	Result
1	Rope sheave and rope guide pulleys	
2	Hinged steel band assembly	
3	Guide block	
4	Rope separator	
5	Carabiner	
6	Device casing	
7	Buttons, battery level indicator light, speed/direction thumb shifter, remote control/intercom	
8	Fastening screw on rope sheave	
9	Battery	
10	Rope	
11	Others	
Inspection conclusion		
Inspected by (Signature)		

ASAT powered ascending device annual inspection record sheet

Customer :		
Product name		
Model/Serial Number		Inspection site
		Inspection date
No.	Inspection item	Result
1	Rope sheave and rope guide pulleys	
2	Hinged steel band assembly	
3	Guide block	
4	Rope separator	
5	Carabiner	
6	Device casing	
7	Buttons, battery level indicator light, speed/direction thumb shifter, remote control/intercom	
8	Fastening screw on rope sheave	
9	Battery	
10	Rope	
11	Others	
Inspection conclusion		
Inspected by (Signature)		

ASAT powered ascending device annual inspection record sheet

Customer :		
Product name		
Model/Serial Number		Inspection site
		Inspection date
No.	Inspection item	Result
1	Rope sheave and rope guide pulleys	
2	Hinged steel band assembly	
3	Guide block	
4	Rope separator	
5	Carabiner	
6	Device casing	
7	Buttons, battery level indicator light, speed/direction thumb shifter, remote control/intercom	
8	Fastening screw on rope sheave	
9	Battery	
10	Rope	
11	Others	
Inspection conclusion		
Inspected by (Signature)		









SKYER (Beijing) Industry Technology Co.,Ltd.
26B, West Zone, LianDo U Valley, No.17 Huan Ke Zhong Lu,
Tong Zhou District, Beijing, PR China 101102
Tel: +86-10-59770510
[Http://www.asatsafe.com](http://www.asatsafe.com)

