



USER INSTRUCTIONS

OBELISK

Code

LPP0003

CE EN 795:2012 Type B

PD CEN/TS 16415:2013 Type B

lyon.co.uk/user-instructions



For more detailed user information and to download a PDF copy of these instructions follow the link above or scan the QR code with your smart phone

Lyon Equipment Limited
Units 3-7, Tebay Business Park,
Old Tebay,
Penrith,
Cumbria, United Kingdom,
CA10 3SS
Tel: +44 (0) 15396 24040
Email: info@lyon.co.uk
Web: lyon.co.uk

© Lyon Equipment 2017



This information to be read and kept for the lifetime of the product in conjunction with the Lyon General User Instructions.

Quality assurance

Quality management system assessed and certified as meeting the requirements of ISO 9001.

Certification

When used for a single person load: CE 0120, EN 795:2012 Type B “Personal fall protection equipment. Anchor devices”.

When used for a two person load: CEN/TS 16415:2013 Type B “Personal fall protection equipment – Anchor devices – Recommendations for anchor devices for use by more than one person simultaneously”.

When used for rescue or a two person load, this item is not classed as PPE and is not covered by PPE Directive 89/686/EEC.

Approved bodies

EC Type-examination for Directive 89/686/EEC by:

Notified Body No. 0321,
SATRA, Wyndham Way, Telford Way,
Kettering, Northamptonshire,
NN16 8SD, UK.

Controlling the manufacturing:

Notified Body No. 0120
SGS United Kingdom Ltd, Unit 202b,
Worle Parkway, Weston-super-Mare,
BS22 6WA, UK.

Working Load Limit (WLL)

Please note that the WLL refers to the total combined load on the OBELISK. The combined load must not exceed this amount.

Where dynamic loads are envisaged, the WLL may be up to 100 kg for a single-user (EN 795:2012) and 200 kg for two-users (CEN/TS 16415:2013).

Where only static loads are applied, the WLL may be up to 272 kg.

The WLL specified above apply when used in configurations described in these User Instructions, with loads suspended from the anchor point and at 90° to the footprint. Alternative rigging layouts, terrain and environmental conditions may apply forces in directions that reduce the stability of the OBELISK. In such circumstances, the WLL must be decreased. Resultant forces that extend beyond the footprint of the OBELISK can cause overturning.

Ultimately, the user of the OBELISK is responsible for determining the WLL of the OBELISK based on the specific circumstances of use and the factor of safety applied. Users may reduce the WLL. The user must never exceed the WLL.

Breaking load

For a single person load:
EN 795:2012 requires a minimum breaking strength of 12 kN.

For a two person load:
CEN/TS 16415:2013 requires a minimum breaking strength of 13 kN.

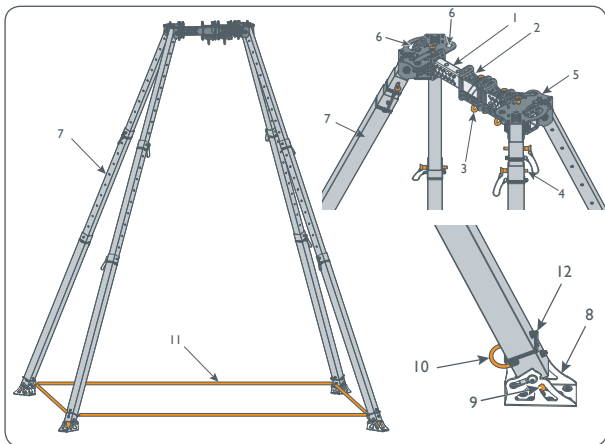

Warning

Where accessories are available refer to the user instructions supplied with the accessories.

Always inspect the OBELISK before use. Refer to instructions for inspection.

A damaged, incorrectly loaded or overloaded OBELISK could fail, causing damage, injury or death.

When carrying out work at height maintain an appropriate exclusion zone.

Remain vertically below the anchor point to minimise the risk of a pendulum fall which may apply loads outside the footprint of the OBELISK, shock load it or destabilise it.

The OBELISK will transmit any force applied directly to the structure in the direction in which it is applied. The OBELISK will attempt to align with any applied force, and may move if the load is not applied perpendicular to the structure.

Never adjust any part of the OBELISK once it has been deployed and is in use.

Nomenclature of parts

- | | |
|------------------------------|--|
| 1. Top Beam | 7. Leg section (top/middle/bottom) |
| 2. Carriage(s) | 8. Foot |
| 3. Swivel Anchor Point | 9. Spike |
| 4. Locking Pin | 10. Leg Restraint Strap Attachment Point |
| 5. Leg Carrier | 11. Leg Restraint Strap |
| 6. Guy Line Attachment Point | 12. Foot lock |

Use

The OBELISK is intended to provide an elevated anchor point(s) for combined loads not exceeding 272 kg, within the limits and restrictions defined by these User Instructions.

For single-user use, the OBELISK is Personal Protective Equipment, and may be a personal issue item. For two simultaneous users or during rescue, the OBELISK is not Personal Protective Equipment. Please note, for all uses, the OBELISK is **NOT** lifting equipment.

Always know the weight of the intended load before using the OBELISK. Do not overload the OBELISK.

Under normal operating conditions, the OBELISK will not show any obvious deflection.

Always ensure that the surface the OBELISK is to be used upon is capable of withstanding the foreseeable loadings applied by the OBELISK. The surface on which the OBELISK is placed may dramatically reduce both the WLL and the stability of the OBELISK, e.g. if there are overhangs, undercuts, voids, slippery and/or sloping surfaces, free flowing solids.

Always ensure the OBELISK is of a suitable size, shape and configuration for the intended use.

The OBELISK can be used with differential leg adjustments in any combination, e.g. short front legs and long back legs, or short side legs and long side legs. Ensure that the upper surface of the Top Beam is level in the horizontal planes.

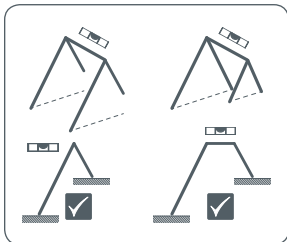

NOTE: It is not the intention of these user instructions to describe the numerous alternative systems that may be connected to the OBELISK. It is the responsibility of the user to check compatibility with the other elements in the safety chain before using this product. The performance of the elements of the safety chain must not be compromised when the OBELISK is installed and in use.

Assembling the OBELISK

Assemble the OBELISK a safe distance from any fall hazard.

Users are responsible for ensuring their own safety whilst assembling, erecting and using the OBELISK.

The OBELISK may be assembled as follows:

1. Adjust all legs to the expected operating height and secure with the attached locking pins. Do not over extend the legs beyond the warning signs.

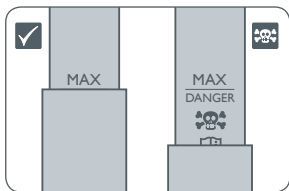

NOTE: To adjust the bottom leg section remove the bottom Locking Pin. To adjust the middle leg section, remove both Locking Pins.

2. After assessing the proposed location, select the foot option most appropriate for the surface (Foot or Spike). Select Spikes when on uneven surfaces. When feet are used, ensure the feet are flat on the surface.

3. Correctly orientate one Leg Carrier to allow insertion of the Top Beam. Slide the Top Beam into the Leg Carrier, adjust the Top Beam to the expected width position and secure with the attached Locking Pin.

4. Slide the Carriage onto the Top Beam, adjust to the expected position (normally the centre of the Top Beam) and secure with the attached Locking Pin. No more than two Carriages are permitted on the Top Beam.

5. Correctly orientate the second Leg Carrier to allow insertion of the Top Beam. Slide the Leg Carrier onto the Top Beam, adjust the Leg Carrier to the expected width position and secure with the attached Locking Pin.

6. At this point it may be appropriate to attach the required rigging or personal fall protection equipment to the Swivel Anchor Point(s). Be aware that once the OBELISK is raised into its working position these points may be out of reach.

7. Using additional personnel, if required, raise the OBELISK upright by lifting the two legs positioned away from the ground and then raising the head assembly upwards, allowing the OBELISK to pivot on the lower feet into an upright position.

TAKE CARE - MANUAL HANDLING AND ENTRAPMENT RISK DURING THIS OPERATION.

IF THE HEIGHT OF THE OBELISK REQUIRES ADJUSTMENT ONCE IN THE UPRIGHT POSITION, ALWAYS HOLD THE LEG SECTIONS ABOVE THE LEG BEING ADJUSTED TO PREVENT COLLAPSE WHEN REMOVING THE LOCKING PIN(S).

8. Re-check all connections and Locking Pins are securely fitted before moving the OBELISK into the working position.

9. Move the OBELISK into the working position, whilst maintaining the safety of the users.

10. Position the legs so that the indicators on each leg carrier line up with the leg. This ensures the OBELISK is set up with the legs at the approved angle.

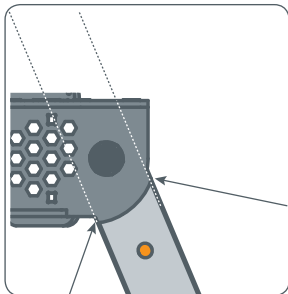

11. Install the Leg Restraint Straps (see section Leg Restraint Straps). Ensure the straps are adjusted so that all slack is removed. Where undulations or obstructions on the worksite surface prevent a clear path for the Leg Restraint straps the relevant straps must be adjusted such that the stability of the OBELISK is maintained throughout the activity. Where the strap is forced over an object causing the strap to raise one leg off the surface, the OBELISK must be repositioned.

The OBELISK must never be used without all four Leg Restraint straps correctly fitted and adjusted.

Leg Restraint Straps

Leg Restraint Straps are essential for the structural stability of the OBELISK. They must be used at all times, in all configurations.

The ultimate load capacity of the OBELISK depends on the ability to secure the feet against movement by correct use of the Leg Restraint Straps.

In addition to using the Leg Restraint Straps, it may be appropriate to securely attach the feet to the surface, e.g. concrete slab, to prevent movement of the OBELISK. Direct attachment of the feet must not be used as a substitute for correct OBELISK placement (risk of overloading).

To attach the Leg Restraint Strap, clip one of the sewn-in quick links onto the Leg Restraint Strap Attachment Point on one leg. Extend the strap via the adjustment buckle and attach the second quick link onto the Leg Restraint Strap Attachment Point on the second, adjacent leg (see figure below). Do not attach diagonal facing legs together.

Repeat the process until all legs are linked in a rectangle.



Grasp the tail end of the webbing exiting each adjustment buckle and pull, tightening the strap to remove any slack. Tighten all four straps evenly to maintain a rectangular foot and ensure the OBELISK is set up with the legs at the approved angle (see 10).

Guy Line Attachment Points

When used as described above, guy lines are not required. However, in some circumstances, the user may wish to maintain the stability of the OBELISK by fixing guy lines to the identified Guy Line Attachment Points. Guy lines must not be used as a substitute for correct OBELISK placement.

Suitable EN 362 locking connectors must be used to attach the guy line to the Guy Line Attachment point.

Do not attach any part of the safety system to the Guy Line Attachment Points.

Attachment of personal fall protection equipment

Only attach the rigging or personal fall protection equipment to a Swivel Anchor Point using a compatible EN 362 connector.

No more than two Carriages are permitted on the Top Beam.

Storage and transport

A storage and transport bag is available for the OBELISK.

It is recommended that the OBELISK is stored, clean and dry when not in use – see maintaining your equipment.

The total weight of the OBELISK is 21 kg. It should be classed as a two person load when transporting manually.

The accessory transport bag is provided with a number of carrying handles. Transport bags are not rated as lifting

accessories - do not use the handles for lifting, lowering or suspending the bag and its contents at height.

Inspection

The OBELISK should be subject to:

- Pre-use checks
- Thorough inspections (at least once every 6 months)
- Interim inspections (as appropriate)

The checks should be undertaken in good light. Any item showing any defect should be withdrawn from service immediately.

If in any doubt as to the condition of the product, it should be withdrawn from use immediately and not used again unless confirmed by a competent person that it is acceptable to do so.

It is recommended the OBELISK is marked with the date of the next or last inspection.

Check that any labels and markings are still intact and readable.

The OBELISK and any accessories should be checked for signs of overloading and damage including wear, corrosion, cracking, weld failure, abrasion or deformity - list not exhaustive.

Metal items - Leg Carriers, Top Beam, Carriage, Spike, Feet inspection

Check for signs of overloading and damage including wear, corrosion, cracking, weld failure, abrasion, sharp edges or deformity. Pay special attention to the anchor points and all welded joints.

Ensure the Swivel Anchor Point functions correctly and is free from damage.

Ensure there are no sharp edges or burrs on the Guy Line Attachment Points. Any burrs or sharp edges may be removed with the use of emery cloth.

Assemble the Leg Carriers, Top Beam and Carriage. Check the individual sections slide without binding or excessive play. Locking pins should fit without force in every adjustment position.

Metal items – Leg inspection

Ensure that the legs are not split, deformed, corroded or cracked.

The individual sections should slide without binding or excessive play. Locking pins should fit without force in every adjustment position.

Check the leg hinge assembly (bolt, nut, washers) for security. The hinge assembly should allow movement without binding or excessive play.

Check the security and function of the Leg Restraint Attachment Point, Feet and Spikes.

Metal Items - Locking Pin inspection

Check that release button moves freely and that locking detent balls move in and out when the release button is operated.

Check that the Locking Pin is not bent or dented by installing the Locking Pin into a pin placement; it should move freely in and out of the placement whilst the release button is depressed.

Check Locking Pin security in each pin placement by attempting to pull the locking pin out of the placement without depressing the release button; if removal is possible without depressing the release button, do not use and quarantine the Locking Pin and Leg immediately. Retire defective component(s).

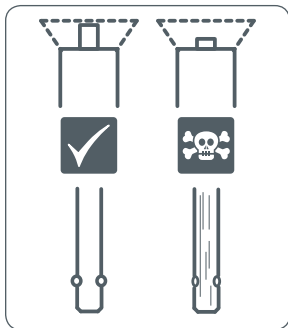

Figure shows left pin in good working condition. The right pin should be retired due to wear and detent pins not properly working.

Textile items - Leg Restraint Straps

The Leg Restraint Strap must be complete with all end connections, and must fully adjust and lock over its full range of adjustment.

Check the webbing visually and by passing the straps slowly through the hands to detect damage, e.g. cuts in the edges of the webbing, abrasion, cuts across the face of the webbing, softening or hardening of fibres, ingress of contaminants, broken, cut and worn threads in the stitching. Pay particular attention to areas where the webbing is in contact with connectors, buckles and the Leg Restraint Strap Attachment Point. Check the webbing for discolouration, which could be the result of chemical or UV damage.

The metallic elements should be inspected for correct function, signs of overloading and damage, e.g. wear, corrosion, cracking, weld failure, abrasion, sharp edges, deformity.

Any of these defects may affect the performance of the OBELISK.

Lubrication

All leg hinge assemblies and Locking Pins should be lightly lubricated after each use. Use a liquid lubricant with good adhesion, e.g. light machine oil.

Apply sparingly and wipe off any excess.

Chemicals

If the OBELISK comes into contact with any chemicals or contaminants, including biohazard, remove it from service and quarantine.

Taking appropriate precautions, clean the metallic parts of the OBELISK to remove the contaminants and prevent contamination of other items in the safety chain.

Ensure beforehand that the cleaning process and cleaning materials will not damage the OBELISK.

All textile parts in contact with chemicals or contaminants, including biohazard cannot be effectively cleaned and must be destroyed.

Spare parts and repairs

A limited number of spare parts are available for user-fitment. A repair service is also offered. Contact the manufacturer for details.

Accessories

A range of accessories are available for the OBELISK. See www.lyon.co.uk for information.

Materials

The body of the OBELISK is made from stainless steel.

The legs are made from aluminium alloy. The locking pins are made from stainless steel.

The leg restraint straps are polyester.

The leg restraint strap quick links are steel.

The leg restraint strap adjustment buckles are aluminium alloy.

Customer's own marking/serialisation



Marking, if required, can be made by attaching a tag to the OBELISK. Ensure that any tags do not interfere with the function or performance of the OBELISK.





Markings

In addition to the markings shown overleaf, the OBELISK is made up from several parts. Each part is marked for traceability. The table below may be used to record these markings.

The serial number of the OBELISK can be found on a sticker on each Leg Carrier.

Part	Description of marking/location	Type of marking	Record here the Serial No. / idN No. / Batch No.
OBELISK	Two identical stickers on two Legs	Serial No.	
Supplied with the OBELISK			
Leg Carrier	5 digit laser-etch on the top of each Leg Carrier	Batch No.	
Leg Carrier			
Leg	5 digit laser-etch at the bottom of each Leg	idN No.	
Leg			
Leg			
Top Beam 0.5 m		idN No.	
Carriage		idN No.	
Accessories available for the OBELISK			
Top Beam 0.3 m		idN No.	
Carriage		idN No.	

	Manufacturer's logo
	Refer to user instructions
CE0120	CE mark and notified body controlling manufacture. Only applicable to EN 795:2012
EN 795:2012 Type B	PPE standard to which this items conforms when used with one person
CEN/TS 16415:2013 Type B	Technical Specification to which this item conforms when used with two persons simultaneously
idN	Individual serial number will be in the format YYDDD 12345. The first two digits give the year of manufacture, the next three digits the day of the year from 001 to 365 and the five digits after is the number in the series

	Number of simultaneous uses permitted when used in accordance with EN 795:2012
	Number of simultaneous uses permitted when used in accordance with CEN/ TS 16415:2013
MAX	Maximum leg extension has been reached
DANGER 	Warning: maximum leg extension has been exceeded
 mm-yyyy	Month and date of manufacture. The first two digits give the month of manufacture, the last four give the year.
	Guy Point Attachment - not an anchor point
LPP0003	Product code

End of document.

Lyon Product Inspection Record

Product code Length if applicable	Product description Individual serial number	Year of manufacture Date of first use	Purchase date Certificate of conformity number	Other relevant information
Manufacturer Lyon Equipment Ltd.	Address Unit 3-7 Tebov Business Park Old Tebov Penrith CA10 3SS UK	Tel: +44 (0)15396 24040 Fax: +44 (0)15396 26330 info@lyon.co.uk lyon.co.uk		
Record of inspection and repair				
Date	Comments	Name and signature of competent inspector	Next due date	
All user instructions supplied with this product must be kept as part of the product inspection record				



General user instructions

Lyon Equipment Limited
Units 3-7, Tebay Business Park,
Old Tebay,
Penrith,
Cumbria, United Kingdom,
CA10 3SS

Tel: +44 (0) 15396 24040
Email: info@lyon.co.uk
Web: lyon.co.uk

© Lyon Equipment 2014-2015

lyon.co.uk/user-instructions

For more detailed user
information and to
download a PDF copy
of these instructions
follow the link above or
scan the QR code with
your smart phone



WARNING

Make sure that you have read and understood these instructions before using this equipment. These user instructions are to be read and kept along with any other user information provided.

Activities at height are hazardous and may lead to injury or death. It is the user's responsibility, at all times, to ensure that they understand the correct use of any equipment supplied by or through Lyon Equipment, use it only for the purposes for which it is designed, and practice proper safety procedures including having a rescue plan in case of emergency.

This product must not be used outside its limitations, or for any purpose other than those described in the user instructions. Misuses forbidden in these instructions are examples only; many other misuses may exist which could lead to injury or death.

Please note, the information in these user instructions is not exhaustive, and is not a substitute for comprehensive instruction and training by a competent person.

Lyon Equipment is not responsible for any consequences, whether direct, indirect or accidental, resulting from the use of its products. If you are unsure about the correct use of this product, please contact us.

Who can use this equipment

This equipment should only be used by trained, competent and responsible persons, or the user should be under the direct supervision of a trained, competent and responsible person.

Activities at height should not be undertaken by persons affected by alcohol or drug dependence, diabetes, epilepsy, fits, blackouts, fear of heights, vertigo / dizziness / difficulty with balance, heart disease / chest pain, high or low blood pressure, impaired limb function, obesity, psychiatric illness, musculoskeletal issues, e.g. a bad back.

General instructions for use

Equipment must be checked before each use, to ensure it is serviceable and operates correctly. Checks should also be carried out during use. In addition, a thorough inspection by a competent inspector should be carried out in strict accordance with these user instructions, and a record kept of these inspections.

This product may be used with any compatible item of Personal Protective Equipment (PPE) which conforms to the European Union Directive 89/686/EEC, keeping in mind the limitations of each item in the safety chain. It should be noted that a full body harness is the only type of harness which may be used in a fall arrest system.

The anchor device or anchor point is of primary importance and should be unquestionably reliable. It should be strong enough to withstand the

foreseeable maximum load that could be applied e.g. in the event of a fall.

When selecting an anchor, the anticipated directions of loading and potential loads should be taken into account.

Anchors should be selected and positioned to allow work to be carried out in such a way as to minimise the potential for a fall and potential fall distance, for example by keeping the anchor point / device above the user.

Anchors should not have sharp or rough edges which could damage equipment (use edge protection if necessary).

On each occasion of use, verify the free space required beneath the user in order to avoid an impact. Always try to place protection so that any fall will be stopped before the user hits the ground or any other obstruction. Remember to allow for rope stretch and slippage in the belay device or rope ascender / descender. In a fall arrest situation, the user must be protected from dynamic forces of greater than 6 kN in the event of a fall, e.g. by use of a fall arrest system incorporating an EN 355 energy absorber.

Maintaining your equipment

Wash in clean water not exceeding 30°C with pure soap and rinse in clean cold water. Do not use chemical products, solvents or detergents – these should be regarded as harmful.

Due to the difficulties in effectively disinfecting equipment, we recommend

that any contaminated equipment should be withdrawn from use and disposed of in a suitable manner.

Equipment must be clean and dry before storing. Always allow to dry naturally, away from direct heat. Equipment should be stored in a cool, dry, well-ventilated area, away from excessive heat, high humidity, sharp edges, corrosives, sunlight or other sources of ultraviolet light (UV) and other possible causes of damage.

During transport, this product should be protected from abrasion, mechanical damage, chemical contamination, UV and heat.

Textiles

Always keep textile items at temperatures between -30°C and +50°C.

Metal items

Always keep metal items at temperatures between -20°C and +60°C.

No alterations, additions or repairs may be made to this product without the manufacturer's prior written consent; if done, the repair must be carried out by a competent person for repair authorised by Lyon Equipment to make the repair, and in accordance with specified procedures.

These instructions must be strictly adhered to.

Inspection

A thorough inspection should be carried out at least every 6 months by a competent inspector in accordance with these user instructions. A record of these checks should be kept with the product along with these user instructions. In addition, interim inspections should be carried out where products are used intensively, or in particularly harsh environments where damage is more likely to occur, or where legislation or the type of equipment make it necessary.

Pre-use and thorough inspections are essential because the user's level of protection depends on the continuing correct performance of this product.

PPE (Personal Protective Equipment) inspection training is available from Lyon Equipment.

Lifetime, and when to withdraw your equipment from use

Withdraw your equipment from use if any one of the following applies:

- It shows sign of wear and tear / damage that may affect performance
- Markings on the product are no longer legible
- You suspect it may have been exposed to chemical contamination or extreme temperatures
- It fails a periodic examination
- It has been used to arrest a fall or has been excessively loaded

- It is more than 10 years after the date of manufacture (textile items or items with textile components). Metal items have a potentially indefinite lifespan if stored correctly.
- If you have any reason to doubt that it is safe to use.

It is the responsibility of the competent inspector to decide whether the equipment should be put back into use, or permanently withdrawn from use. Equipment permanently withdrawn from use must be destroyed, and should be recycled where facilities exist.

Certain environmental elements will considerably accelerate wear: salt, sand, dust, snow, ice, moisture, chemicals, sunlight (UV radiation) – list not exhaustive.

Warning: the safe working life of this product may be as short as its first use in extreme circumstances.

If in doubt, do not hesitate to scrap this product.

Guarantee

In the event of any defect in materials or workmanship please return the product to the dealer, distributor or manufacturer within 3 years of purchase for inspection. We will replace or repair as required. This guarantee does not cover normal wear and tear or accidental damage.

Note to resellers

If the product is re-sold outside the UK and Ireland, but within the EU, the reseller is responsible for providing instructions for use, maintenance, periodic examination and for repair in the language of the country in which the product is to be used.

If you require the Intrastat commodity code / customs tariff code or NATO stock number (where applicable) for this product, please contact us via lyon.co.uk









Inspection records

A record must be kept for each component, subsystem and system, including name and contact details of the manufacturer or supplier, product description, serial number, year of manufacture, date of purchase, date of first use, any other relevant information, and history of periodic examinations and repairs, the name and signature of the competent inspector and the next due date for inspection. An example of a suitable equipment record is shown on this user instruction and can also be downloaded at lyon.co.uk

Local jurisdiction may dictate that extra information be recorded in the inspection record – check your country's legal requirements. Some products may have features which need special monitoring during periodic inspections, e.g. wear indicators, in which case this information should also be recorded on the inspection record.

This page deliberately left blank

Explanation of symbols

	Refer to user instructions
	Permitted use
	Caution
	Danger of death
	Telephone number
	Anchor point
	Rope diameter
	Cable
	SWL (Safe Working Load)

Lyon Product Inspection Record

Product code		Product description		Year of manufacture	Purchase date
Length if applicable		Individual serial number		Date of first use	Certificate of conformity number
Manufacturer <i>Lyon Equipment Ltd.</i>	Address <i>Unit 3-7 Tebov Business Park Old Tebov Penrith CA10 3SS UK</i>		Other relevant information <i>Tel. +44 (0)15396 24040 Fax. +44 (0)15396 26330 info@lyon.co.uk lyon.co.uk</i>		

Record of inspection and repair

Date	Comments	Name and signature of competent inspector	Next due date

All user instructions supplied with this product must be kept as part of the product inspection record