



▪ ANCHORAGE ▪

Product Description

Product Name: DW100

Product Standard: BS EN 795: 2012

Product Description: Mild Steel construction with orange powder coated finish



Materials used

Sword pins: Mild Steel Zinc Plated

Rollers: White Nylon

Wheels: Elastic Rubber on black Nylon

Frame: Mild Steel

Eye Bolts: Galvanised white coated stainless

Component Parts

The DWT is supplied with 6 x 25kg weights, **ALL** of which must be used at all times.



▪ ANCHORAGE ▪

ANCHORAGE SYSTEMS

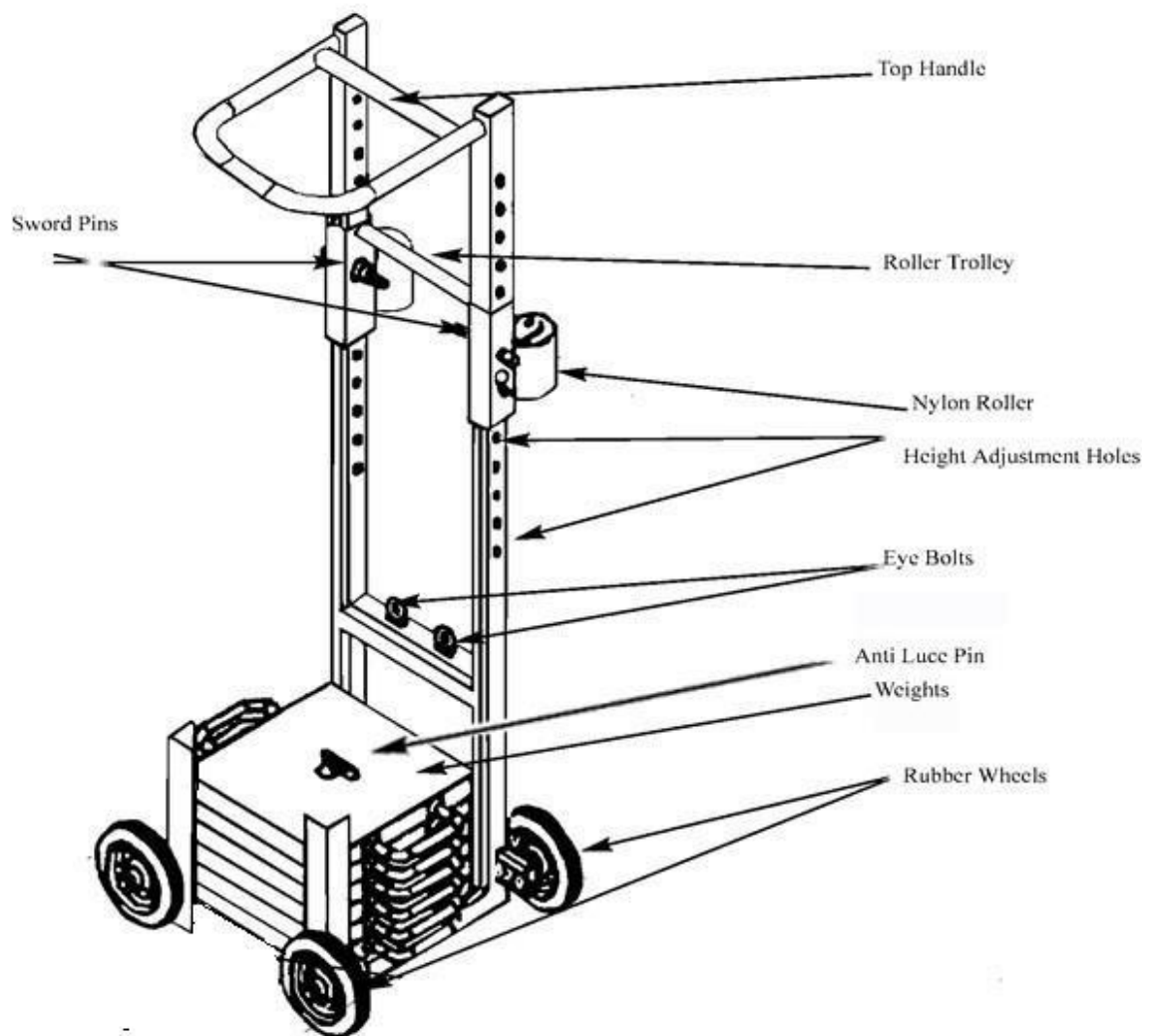

DEAD WEIGHT TROLLEY

MUST USE ALL SIX WEIGHTS AT ALL TIMES.



▪ ANCHORAGE ▪

Conformity and Markings

Conformity

- Your DWT conforms to BSEN795:2012 Type E, tested by SATRA and CE marked accordingly. The DWT has been designed to be used for industrial rope access and fall arrest purposes.
- The DWT has passed further testing to meet the requirements of mbs 15kn, IRATA and SPRAT ICoP requirement that anchors for rope access must meet a 15kN static test.
- The DWT has been designed to be used behind a parapet wall ranging in height from 600mm to 1200mm.*
- The DWT is for use by one person UNLESS a rescue needs to take place.
- The DWT has a safe working load 250kg and can be used in a rescue situation.
- The DWT is supplied with a test certificate that details the date of the first and next inspection.
- The DWT displays the date of next inspection on the tags secured on the base of the eye bolts.

* Please note, where we recommend a minimum upstand of 600mm, the Deadweight anchor was tested at 450mm. If used at 450mm, this will make the use of the rollers redundant.

Meaning of markings

CE0120: conformity to the European directive, including number of the notified body.

Serial Number: DWT month of manufacture year of manufacture and test cert no.

Notified Body 0321

SATRA Technology
Wyndham Way
Kettering
NN16 8SD



▪ ANCHORAGE ▪

DWT ID Plate

The ID plate is situated on the bar where the eye bolts are placed. The ID plate sits below on the front facing side.

1	2	3
Manufacturer SAS Anchorage	SAS Anchorage 01793 644908 www.sasanchorage.com	Product Deadweight Trolley
4	CE 0120  EN795 : 2012 Type E MBS 15KN	
Serial No. SAS 000---	Model & Type/Identification DW100	S.W.L 250kgs
5	6	7

1 – Manufacturing Company

2 – Company contact details

3 – Product Name

4 – Conformity Markings

5 – Specific serial number assigned to each individual trolley

6 – The trolley's product code

7 – S.W.L = Safe Working Load limit of 250kgs



▪ ANCHORAGE ▪

IN USE

This equipment must never be used outside its limitations, or for any other purpose than that which it was designed.

Use as part of a system

- The DWT is designed to be used as part of a system. In fall arrest, it must be used with the appropriate equipment i.e. fall arrest lanyard and full body harness only and in rope access with a twin rope system and work positioning harness only and associated equipment.
- For rope access, standard requirements refer to BS7985:2002, BS EN12841:2006 and BS7883. For fall arrest, standard requirements refer to BS EN355 and BS EN361

Rescue

The DWT has a safe working load of 250kg and can be used in a rescue situation. This is when two people are allowed to use the anchor at the same time in accordance with PD CEN/TS 16415: 2013

Documentation/Testing/Periodic Examinations

- The DWT is issued with a proof load test certificate valid for six months and must be tested six-monthly by a competent person. The safety of users depends upon the continued efficiency and durability of the equipment.
- A visual examination of the DWT is recommended before each use.
- The legibility of the ID plate (located under the eye bolts).
- A record card is kept by the manufacturer with a copy certificate issued to the user.

Training

- Users of this equipment shall be able to demonstrate either in-house expertise or hold suitable training certificates in fall arrest /industrial rope access.
- Working at height is dangerous, all personnel should be trained and competent with working at height.
- If there are any doubts regarding the safe condition and use of this equipment or if it has been involved in a fall situation, it should be withdrawn from use immediately.



▪ ANCHORAGE ▪

Calculating the Point Load of the DW100

A distributed load is a force spread over a surface or line, which can be expressed in terms of force per unit area, such as kilonewtons (kN) per square meter. A point load is an equivalent load applied to a single point, which you can determine by calculating the total load over the object's surface or length and attributing the entire load to its centre.

Determine the total length or area to which a load is applied. For example, if a load of 10 kilonewtons (kN) per square meter is applied to an area measuring 4 meters by 6 meters, then the total area is 24 square meters. If a load of 10 kN per meter is applied to a beam measuring 5 meters in length, then the total length is merely 5 meters.

Determine the centre of the area or length. If you plot the 4-by-6-meter rectangle with its lower left corner at the origin and its length along the X-axis, then its corners are at (0,0), (6,0), (6,4) and (0,4), and its centre is at (3,2). The centre of a 5-meter beam is 2.5 meters from either end.

Multiply the load per unit area or length by the total area or length. For the rectangle, you compute 10 kN per square meter multiplied by 24 square meters to get 240 kN. For the beam, you calculate 10 kN per meter multiplied by 5 meters to get 50 kN.

Write your answer as the total load in Step 3 applied to the point you determined in Step 2. For the rectangle, the point load is 240 kN applied to a point 3 meters from an end in the length dimension and 2 meters from an end in the width dimension. For the beam, the point load is 50 kN applied to a point 2.5 meters from either end

Tip:

You can use this general method for any shape if you can determine its centroid (the centre of its mass) and total area. For example, the centroid of a circular area of uniform mass is its centre, and its area is pi times the square of its radius.



▪ ANCHORAGE ▪

Pre-Use Checks

- **Eye bolts:** ensure all eye bolts are securely attached, no visible signs of cracks.
- **ID Discs:** ensure these are present and in date.
- **Weights:** ensure all weights are in place and secured.
- **Sword pins:** ensure all sword pins are secured in place and in working order.
- **Rollers:** ensure all rollers are in working order and secure.
- **Wheels:** ensure all wheels are functioning and secure.

Essential for Safety

The DWT must be withdrawn from use immediately should:

1. Any doubt arises about its condition for safe use.
OR
2. It has been used to arrest a fall.

AND not used again until confirmed in writing by a competent person that it is safe to do so.

It is essential when being used for fall arrest, to verify the distance required in the event of a fall before each use so there will be no collision with the ground or other obstacles in the fall path.
i.e Length of lanyard plus karabiner = 1.5m extension of energy absorber = .7m, distant between tie in point and workers feet = 1.5 m and a min post ground clearance of 1m, therefore a minimum ground clearance of 4.7m is required.

Manual Handling/Lifting

Due to the weight of the body and of component parts, it is recommended that gloves and steel toe boots are worn when handling and correct lifting techniques are adopted.

Medical Conditions

All candidates working with this product must be physically fit and free from any disability or medical conditions that may prevent them from working safely.

Installation

Please ensure that the surface in which the deadweight will be used is safe and clear. This is to include surface material, water, ballast, and any foreign material with any loose materials being removed as this could affect the frictional resistance of the deadweight.



▪ ANCHORAGE ▪

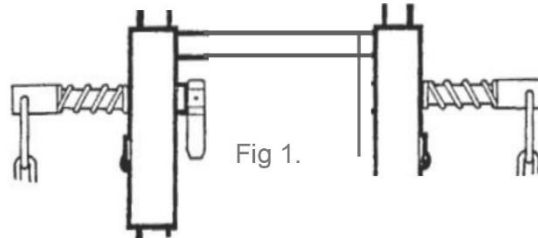
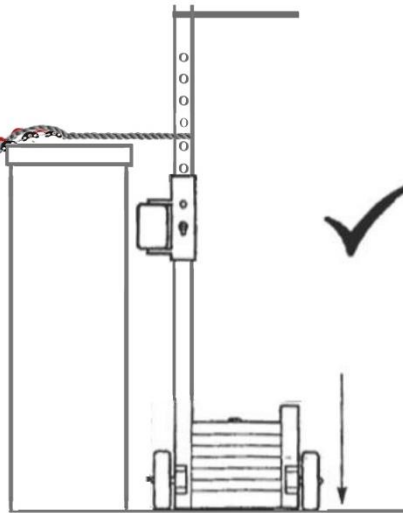

Fig 1.

Always use both pins

Fig 2.
Use rope protectors



All rigging must conform with IRATA ICOP

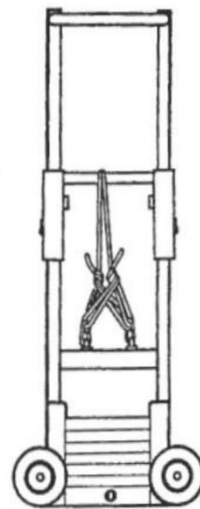
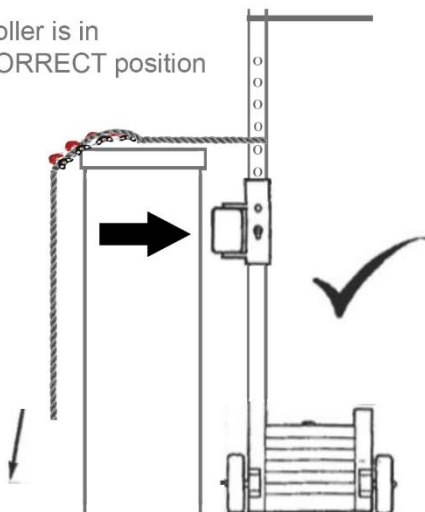
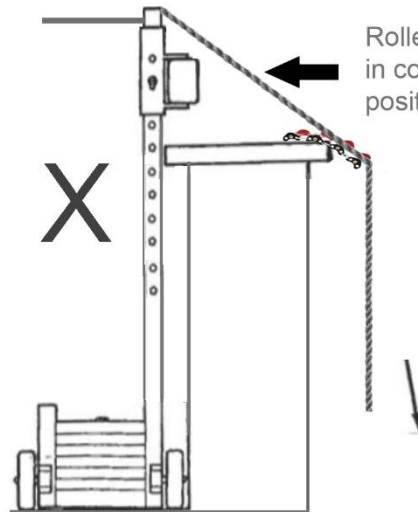

Fig 3.

Roller is in CORRECT position



Roller is NOT in correct position





▪ ANCHORAGE ▪

Warnings:

- In a fall arrest situation, the DWT must be used so that the operator is in line with the equipment's direction of fall and does not incur a pendulum.
- When the DWT is used as part of a fall arrest system, the user shall be equipped with the means of limiting the maximum dynamic forces exerted on the user during the arrest of a fall to a maximum of 6kN.
- The DWT should only be used for the personal fall protection equipment and not for lifting equipment, EXCEPT when using SAS Winch Mounting System. Please note: When using the SAS Winch Mounting System, leading edge protection must be used i.e. Lyon Edge Guard or Petzl Caterpillar.
- Any alterations to the main or any component parts of the DWT are strictly prohibited.
- The DWT must never be used in conjunction with any other piece of equipment that may impede its safe operation, or the safe operation of any other piece of equipment.
- The DWT is designed for the load to be applied vertically downwards from the two Anchor Points, in a plumb line from anchor point to abseiler. No amount of lateral deflection is acceptable. Any displacement in the anchor points must be reported immediately and the DWT withdrawn from service. The anchorage must not be used again until it has been re-certified and confirmed in writing by a trained and competent person.
- If the DWT is re-sold, it is essential that instructions for use, maintenance/repair, periodic examination details and certification accompanies the DWT in the language of destination.
- If the marking of the DWT is not accessible after installation, additional marking near the DWT is recommended.
- A rescue plan should be in place to deal with emergencies that could arise during each use of the DWT.
- This equipment must never be used outside its limitations or for any other purpose than that which it was designed.



▪ ANCHORAGE ▪

Transportation

- Remove all weights from the DWT in transportation.
- Secure weights and frame so no movement occurs in transport.
- Inspect the DWT after transportation and before use.

Cleaning /Maintenance/Storage

- The DWT is finished with a powder coating that can be wiped clean. This will chip over time and it is recommended any exposed metal is kept rust free and touched up with a suitable paint.
- It is recommended that all working parts are lubricated on a periodic basis with a suitable lubricant - WD40 or similar.
- It is recommended that the DWT is stored under cover over night and in the event that it becomes wet it is dried in a well-ventilated area away from direct heat.
- DWT covers are available from our Accessories range.

Life Span

- In normal use, the DWT has an in-use life span of ten years however this can be severely reduced in the event of a fall and must be withdrawn from use if any irregularities are detected during daily pre-use checks or at a six-monthly inspection.
- The DWT can be used on various roof surfaces however, consideration should be given to weight loadings. Any corrugations may require the use of load spreading boards.
- The DWT trolley is designed to be used up against a wall. The roller trolley should be adjusted to the height of the wall so the top bar of the trolley is just higher than the copings. (See diagrams).
- This equipment does not have to be personally allocated to a competent person however all users must be competent in its safe use.

Repair of product

- The end user must not make alterations or additions to the DWT without SAS Rope & Rail Ltd's prior written consent.
- The end user may only carry out repairs/ replacement to rollers, wheels and sword pins (see repair instructions below).
- All other repairs are to be carried out by the manufacturer or competent persons authorised by the manufacturer.



▪ ANCHORAGE ▪

Repair instructions

Sword pins:

Prize open dolston washer with a flat headed screwdriver, insert chain link of new sword pin and close dolston washer using a soft faced hammer.

Rollers:

Remove securing bolts and replace rollers, re-secure bolts ensuring washers are used.

Wheels:

Remove split pins and washers, replace the wheel/s and re-secure using new split pins.

Accessories

Deadweight covers are available directly from us. They are a smart addition to the Deadweight to keep the anchor protected from any weather and possible damage or scuffs whilst not in use.

In the case that your anchor does suffer any superficial damage and you would like to touch up the exterior, we are also happy to provide the touch up paints for your anchor.



Please call us on 01793 644908 to discuss further.

For instructional videos on how to set up and use both the A-Frame and Deadweight trolleys, please head to www.youtube.com and search SAS Anchorage. Members of our Rope Access team will guide you through.